

- A. Citizens of Columbia County
- B. Elected and Constitutional Officials
- C. State supported services and organizations
- D. Regional Partnerships
- E. Local Partnerships
- F. County Boards and Authorities
- G. County Administrator and direct reports
- H. Committees that report to the Board of Commission
- I. County Divisions



# Information Technology

August 2009



Department of Deputy County Administrator

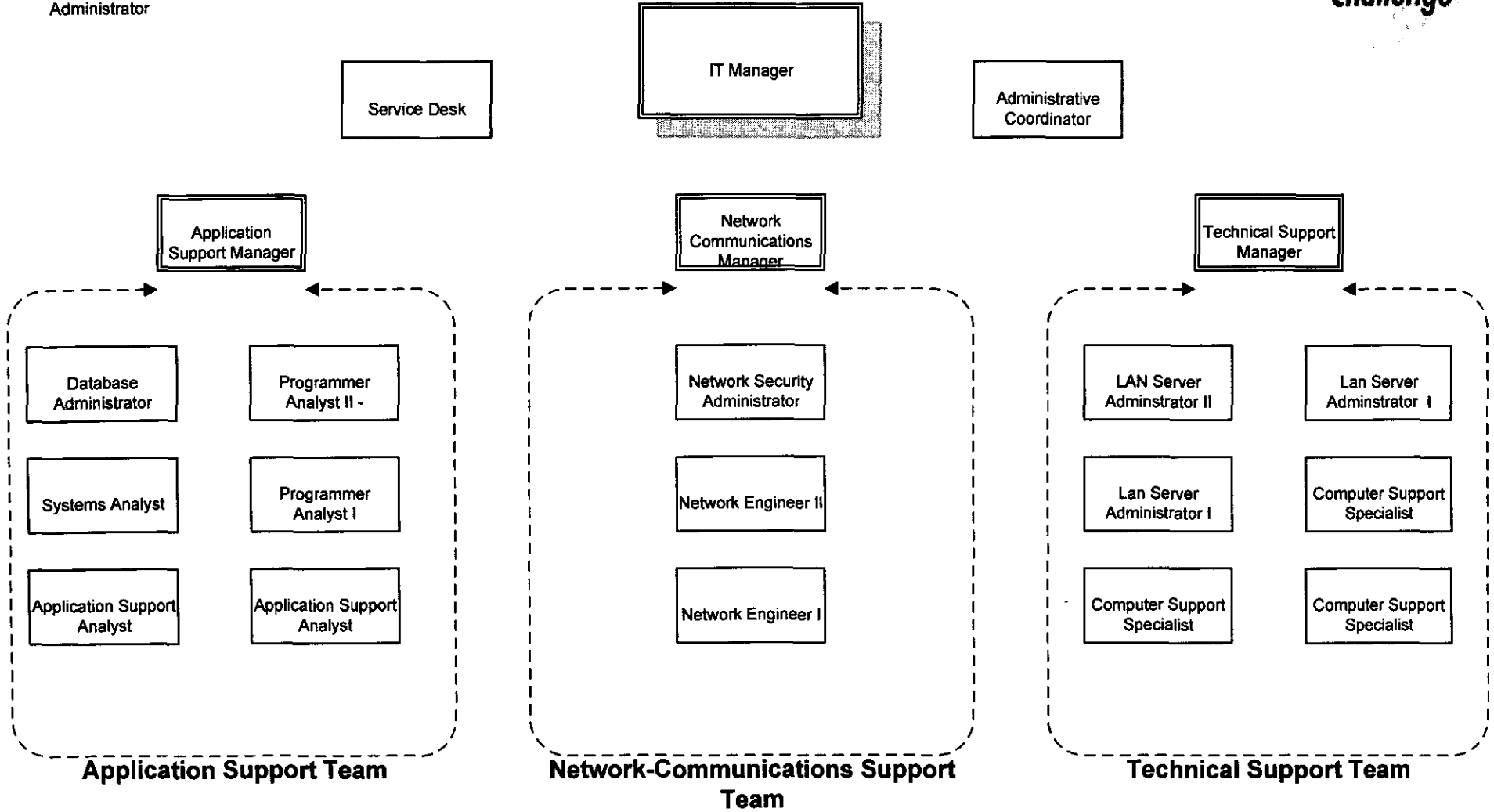

Certification Requirements for BTOP

---

---

**U.S. Department of Commerce**  
**Broadband Technology Opportunities Program**

---

---

I certify that I am the duly authorized representative of the applicant organization, and that I have been authorized to submit the attached application on its behalf. A copy of the applicant organization's authorization for me to submit this application as its official representative is on file in the applicant's office, and I am identified as the applicant organization's Authorized Organization Representative (AOR) in the Central Contractor Registration database. By signing this certification, I certify that the statements contained in the application are true, complete, and accurate to the best of my knowledge, and that if an award is made, the applicant organization will comply with all applicable award terms and conditions.

8/12/2009

(Date)

Lewis Foster

(Authorized Representative's Signature)

Lewis Foster

Name:

IT Manager

Title:

**CERTIFICATION REGARDING LOBBYING  
LOWER TIER COVERED TRANSACTIONS.**

Applicants should review the instructions for certification included in the regulations before completing this form. Signature on this form provides for compliance with certification requirements under 15 CFR Part 28, "New Restrictions on Lobbying."

**LOBBYING** As required by Section 1352, Title 31 of the U.S. Code, and implemented at 15 CFR Part 28, for persons entering into a grant, cooperative agreement or contract over \$100,000 or a loan or loan guarantee over \$150,000 as defined at 15 CFR Part 28, Sections 28.105 and 28.110, the applicant certifies that to the best of his or her knowledge and belief, that:

(1) No Federal appropriated funds have been paid or will be paid, by or on behalf of the undersigned, to any person for influencing or attempting to influence an officer or employee of any agency, a Member of Congress in connection with the awarding of any Federal contract, the making of any Federal grant, the making of any Federal loan, the entering into of any cooperative agreement, and the extension, continuation, renewal, amendment, or modification of any Federal contract, grant, loan, or cooperative agreement.

(2) If any funds other than Federal appropriated funds have been paid or will be paid to any person for influencing or attempting to influence an officer or employee of any agency, a Member of Congress, an officer or employee of Congress, or an employee of a member of Congress in connection with this Federal contract, grant, loan, or cooperative agreement, the undersigned shall complete and submit Standard Form-LLL, "Disclosure Form to Report Lobbying," in accordance with its instructions.

(3) The undersigned shall require that the language of this certification be included in the award documents for all subawards at all tiers (including subcontracts, subgrants, and contracts under grants, loans, and cooperative agreements) and that all subrecipients shall certify and disclose accordingly.

This certification is a material representation of fact upon which reliance was placed when this transaction was made or entered into. Submission of this certification is a prerequisite for making or entering into this transaction imposed by section 1352, title 31, U.S. Code. Any person who fails to file the required certification shall be subject to a civil penalty of not less than \$10,000 and not more than \$100,000 for each such failure occurring on or before October 23, 1996, and of not less than \$11,000 and not more than \$110,000 for each such failure occurring after October 23, 1996.

**Statement for Loan Guarantees and Loan Insurance** The undersigned states, to the best of his or her knowledge and belief, that:

If any funds have been paid or will be paid to any person for influencing or attempting to influence an officer or employee of any agency, a Member of Congress, an officer or employee of Congress, or an employee of a Member of Congress in connection with this commitment providing for the United States to insure or guarantee a loan, the undersigned shall complete and submit Standard Form-LLL, "Disclosure Form to Report Lobbying," in accordance with its instructions.

Submission of this statement is a prerequisite for making or entering into this transaction imposed by section 1352, title 31, U.S. Code. Any person who fails to file the required statement shall be subject to a civil penalty of not less than \$10,000 and not more than \$100,000 for each such failure occurring on or before October 23, 1996, and of not less than \$11,000 and not more than \$110,000 for each such failure occurring after October 23, 1996.

**As the duly authorized representative of the applicant, I hereby certify that the applicant will comply with the above applicable certification.**

NAME OF APPLICANT

AWARD NUMBER AND/OR PROJECT NAME

*Columbia County Information Technology*

*Columbia County Community Broadband*

PRINTED NAME AND TITLE OF AUTHORIZED REPRESENTATIVE

*Lewis Foster IT Manager*

SIGNATURE

DATE

*Lewis Foster*

*8/12/2009*

### Disclosure of Lobbying Activities

Complete this form to disclose lobbying activities pursuant to 31 U.S.C. 1352  
(See reverse for public burden disclosure)

<p><b>1. Type of Federal Action:</b></p> <p><u>B</u></p> <p>a. contract b. grant c. cooperative agreement d. loan e. loan guarantee f. loan insurance</p>	<p><b>2. Status of Federal Action:</b></p> <p><u>A</u></p> <p>a. bid/offer/application b. initial award c. post-award</p>	<p><b>3. Report Type:</b></p> <p><u>A</u></p> <p>a. initial filing b. material change</p> <p><b>For material change only:</b> Year _____ quarter _____ Date of last report _____</p>
<p><b>4. Name and Address of Reporting Entity:</b></p> <p><input checked="" type="checkbox"/> Prime <input type="checkbox"/> Subawardee Tier _____, if Known:</p> <p>Columbia County Information Technology PO Box 498 Evanston CA 95809</p> <p>Congressional District, if known: <u>CA 10th</u></p>	<p><b>5. If Reporting Entity in No. 4 is Subawardee, Enter Name and Address of Prime:</b></p> <p>Congressional District, if known:</p>	
<p><b>6. Federal Department/Agency:</b></p> <p>US Department of Commerce</p>	<p><b>7. Federal Program Name/Description:</b></p> <p><u>BTOP</u></p> <p>CFDA Number, if applicable: <u>11,557</u></p>	
<p><b>8. Federal Action Number, if known:</b></p>	<p><b>9. Award Amount, if known:</b></p> <p>\$</p>	
<p><b>10. a. Name and Address of Lobbying Registrant (if individual, last name, first name, MI):</b></p>	<p><b>b. Individuals Performing Services (including address if different from No. 10a) (last name, first name, MI):</b></p>	
<p><b>11. Information requested through this form is authorized by title 31 U.S.C. section 1352. This disclosure of lobbying activities is a material representation of fact upon which reliance was placed by the tier above when this transaction was made or entered into. This disclosure is required pursuant to 31 U.S.C. 1352. This information will be reported to the Congress semi-annually and will be available for public inspection. Any person who fails to file the required disclosure shall be subject to a civil penalty of not less than \$10,000 and not more than \$100,000 for each such failure.</b></p>	<p>Signature: <u>Lewis Foster</u></p> <p>Print Name: <u>Lewis Foster</u></p> <p>Title: <u>IT Manager</u></p> <p>Telephone No.: <u>7069693393</u> Date: <u>8/12/09</u></p>	
<p><b>Federal Use Only</b></p>	<p>Authorized for Local Reproduction Standard Form - LLL (Rev. 7-97)</p>	

### CERTIFICATION REGARDING LOBBYING

Applicants should also review the instructions for certification included in the regulations before completing this form. Signature on this form provides for compliance with certification requirements under 15 CFR Part 28, "New Restrictions on Lobbying." The certifications shall be treated as a material representation of fact upon which reliance will be placed when the Department of Commerce determines to award the covered transaction, grant, or cooperative agreement.

#### LOBBYING

As required by Section 1352, Title 31 of the U.S. Code, and implemented at 15 CFR Part 28, for persons entering into a grant, cooperative agreement or contract over \$100,000 or a loan or loan guarantee over \$150,000 as defined at 15 CFR Part 28, Sections 28.105 and 28.110, the applicant certifies that to the best of his or her knowledge and belief, that:

(1) No Federal appropriated funds have been paid or will be paid, by or on behalf of the undersigned, to any person for influencing or attempting to influence an officer or employee of any agency, a Member of Congress in connection with the awarding of any Federal contract, the making of any Federal grant, the making of any Federal loan, the entering into of any cooperative agreement, and the extension, continuation, renewal, amendment, or modification of any Federal contract, grant, loan, or cooperative agreement.

(2) If any funds other than Federal appropriated funds have been paid or will be paid to any person for influencing or attempting to influence an officer or employee of any agency, a Member of Congress, an officer or employee of Congress, or an employee of a member of Congress in connection with this Federal contract, grant, loan, or cooperative agreement, the undersigned shall complete and submit Standard Form-LLL, "Disclosure Form to Report Lobbying," in accordance with its instructions.

(3) The undersigned shall require that the language of this certification be included in the award documents for all subawards at all tiers (including subcontracts, subgrants, and contracts under grants, loans, and cooperative agreements) and that all subrecipients shall certify and disclose accordingly. This certification is a material representation of fact upon which reliance was placed when this transaction was made or entered into.

Submission of this certification is a prerequisite for making or entering into this transaction imposed by section 1352, title 31, U.S. Code. Any person who fails to file the required certification shall be subject to a civil penalty of not less than \$10,000 and not more than \$100,000 for each such failure occurring on or before October 23, 1996, and of not less than \$11,000 and not more than \$110,000 for each such failure occurring after October 23, 1996.

#### Statement for Loan Guarantees and Loan Insurance

The undersigned states, to the best of his or her knowledge and belief, that:

If any funds have been paid or will be paid to any person for influencing or attempting to influence an officer or employee of any agency, a Member of Congress, an officer or employee of Congress, or an employee of a Member of Congress in connection with this commitment providing for the United States to insure or guarantee a loan, the undersigned shall complete and submit Standard Form-LLL, "Disclosure Form to Report Lobbying," in accordance with its instructions.

Submission of this statement is a prerequisite for making or entering into this transaction imposed by section 1352, title 31, U.S. Code. Any person who fails to file the required statement shall be subject to a civil penalty of not less than \$10,000 and not more than \$100,000 for each such failure occurring on or before October 23, 1996, and of not less than \$11,000 and not more than \$110,000 for each such failure occurring after October 23, 1996.

**As the duly authorized representative of the applicant, I hereby certify that the applicant will comply with the above applicable certification.**

NAME OF APPLICANT

AWARD NUMBER AND/OR PROJECT NAME

*Columbia County Information Technology*

*Columbia County Community Broadband*

PRINTED NAME AND TITLE OF AUTHORIZED REPRESENTATIVE

*Lewis Foster IT Manager*

SIGNATURE

*Lewis Foster*

DATE

*8/12/2009*

**ASSURANCES - CONSTRUCTION PROGRAMS**

Public reporting burden for this collection of information is estimated to average 15 minutes per response, including time for reviewing instructions, searching existing data sources, gathering and maintaining the data needed, and completing and reviewing the collection of information. Send comments regarding the burden estimate or any other aspect of this collection of information, including suggestions for reducing this burden, to the Office of Management and Budget, Paperwork Reduction Project (0348-0042), Washington, DC 20503.

**PLEASE DO NOT RETURN YOUR COMPLETED FORM TO THE OFFICE OF MANAGEMENT AND BUDGET. SEND IT TO THE ADDRESS PROVIDED BY THE SPONSORING AGENCY.**

NOTE: Certain of these assurances may not be applicable to your project or program. If you have questions, please contact the Awarding Agency. Further, certain Federal assistance awarding agencies may require applicants to certify to additional assurances. If such is the case, you will be notified.

As the duly authorized representative of the applicant, I certify that the applicant:

Has the legal authority to apply for Federal assistance, and the institutional, managerial and financial capability (including funds sufficient to pay the non-Federal share of project costs) to ensure proper planning, management and completion of the project described in this application.

Will give the awarding agency, the Comptroller General of the United States and, if appropriate, the State, through any authorized representative, access to and the right to examine all records, books, papers, or documents related to the assistance; and will establish a proper accounting system in accordance with generally accepted accounting standards or agency directives.

Will not dispose of, modify the use of, or change the terms of the real property title, or other interest in the site and facilities without permission and instructions from the awarding agency. Will record the Federal interest in the title of real property in accordance with awarding agency directives and will include a covenant in the title of real property acquired in whole or in part with Federal assistance funds to assure non-discrimination during the useful life of the project.

Will comply with the requirements of the assistance awarding agency with regard to the drafting, review and approval of construction plans and specifications.

Will provide and maintain competent and adequate engineering supervision at the construction site to ensure that the complete work conforms with the approved plans and specifications and will furnish progress reports and such other information as may be required by the assistance awarding agency or State.

Will initiate and complete the work within the applicable time frame after receipt of approval of the awarding agency.

Will establish safeguards to prohibit employees from using their positions for a purpose that constitutes or presents the appearance of personal or organizational conflict of interest, or personal gain.

Will comply with the Intergovernmental Personnel Act of 1970 (42 U.S.C. 4728-4763) relating to prescribed standards for merit systems for programs funded under one of the 19 statutes or regulations specified in Appendix A of OPM=s Standards for a Merit System of Personnel Administration (5 C.F.R. 900, Subpart F).

Will comply with the Lead-Based Paint Poisoning Prevention Act (42 U.S.C. 4801 et seq.) which prohibits the use of lead-based paint in construction or rehabilitation of residence structures.

Will comply with all Federal statutes relating to non-discrimination. These include but are not limited to: (a) Title VI of the Civil Rights Act of 1964 (P.L. 88-352) which prohibits discrimination on the basis of race, color or national origin; (b) Title IX of the Education Amendments of 1972, as amended (20 U.S.C. 1681-1683, and 1685-1686), which prohibits discrimination on the basis of sex; (c) Section 504 of the Rehabilitation Act of 1973, as amended (29 U.S.C. 794), which prohibits discrimination on the basis of handicaps; (d) the Age Discrimination Act of 1975, as amended (42 U.S.C. 6101-6107), which prohibits discrimination on the basis of age; (e) the Drug Abuse Office and Treatment Act of 1972 (P.L. 92-255), as amended, relating to nondiscrimination on the basis of drug abuse; (f) the Comprehensive Alcohol Abuse and Alcoholism Prevention, Treatment and Rehabilitation Act of 1970 (P.L. 91-616), as amended, relating to nondiscrimination on the basis of alcohol abuse or alcoholism; (g) 523 and 527 of the Public Health Service Act of 1912 (42 U.S.C. 290 dd-3 and 290 ee-3), as amended, relating to confidentiality of alcohol and drug abuse patient records; (h) Title VIII of the Civil Rights Act of 1968 (42 U.S.C. 3601 et seq.), as amended relating to nondiscrimination in the sale, rental or financing of housing; (i) any other nondiscrimination provisions in the specific statute(s) under which application for Federal assistance is being made; and (j) the requirements of any other nondiscrimination statute(s) which may apply to the application.

<p>Will comply, or has already complied, with the requirements of Titles II and III of the Uniform Relocation Assistance and Real Property Acquisition Policies Act of 1970 (P.L. 91-646) which provide for fair and equitable treatment of persons displaced or whose property is acquired as a result of Federal and federally-assisted programs. These requirements apply to all interests in real property acquired for project purposes regardless of Federal participation in purchases.</p> <p>Will comply with the provisions of the Hatch Act (5 U.S.C. 1501-1508 and 7324-7328) which limit the political activities of employees whose principal employment activities are funded in whole or in part with Federal funds.</p> <p>Will comply, as applicable, with the provision of the Davis-Bacon Act (40 U.S.C. 276a to 276a-7), the Copeland Act (40 U.S.C. 276c and 18 U.S.C.874), and the Contract Work Hours and Safety Standards Act (40 U.S.C. 327-333) regarding labor standards of federally assisted construction subagreements.</p> <p>Will comply with flood insurance purchase requirements of Section 102(a) of the Flood Disaster Protection Act of 1973 (P.L. 93-234) which requires recipients in a special flood hazard area to participate in the program and to purchase flood insurance if the total cost of insurable construction and acquisition is \$10,000 or more.</p> <p>Will comply with environmental standards which may be prescribed pursuant to the following: (a) institution of environmental quality control measures under the</p>	<p>National Environmental Policy Act of 1969 (P.L. 91-190) and Executive Order (EO) 11514; (b) notification of violating facilities pursuant to EO 11738; (c) protection of wetlands pursuant to EO 11990; (d) evaluation of flood hazards in flood plains in accordance with EO 11988; (e) assurance of project consistency with the approved State management program developed under the Coastal Zone Management Act of 1972 (16 U.S.C. 1451 et seq.); (f) conformity of Federal actions to State (Clean Air) Implementation Plans under Section 176(c) of the Clean Air Act of 1955, as amended (42 U.S.C. 7401 et seq.); (g) protection of underground sources of drinking water under the Safe Drinking Water Act of 1974, as amended (P.L. 93-523); and (h) protection of endangered species under the Endangered Species Act of 1973, as amended (P.L. 93-205).</p> <p>Will comply with the Wild and Scenic Rivers Act of 1968 (16 U.S.C. 1271 et seq.) related to protecting components or potential components of the national wild and scenic rivers system.</p> <p>Will assist the awarding agency in assuring compliance with Section 106 of the National Historic Preservation Act of 1966, as amended (16 U.S.C. 470), EO 11593 (identification and protection of historic properties), and the Archaeological and Historic Preservation Act of 1974 (16 U.S.C. 469a-1 et seq.).</p> <p>Will cause to be performed the required financial and compliance audits in accordance with the Single Audit Act Amendments of 1996 and OMB Circular No. A-133, AAudits of States, Local Governments, and Non-Profit Organizations.@</p> <p>Will comply with all applicable requirements of all other Federal laws, executive orders, regulations, and policies governing this program.</p>
--	---

SIGNATURE OF AUTHORIZED CERTIFYING OFFICIAL <i>Lenny Foster</i>	TITLE <i>IT Manager</i>
APPLICANT ORGANIZATION <i>Columbia County Information Technology</i>	DATE SUBMITTED <i>8/12/2009</i>



Certification Requirements for **BTOP**

---

---

**U.S. Department of Commerce**  
**Broadband Technology Opportunities Program**

---

---

(i) I certify that I am authorized to submit this grant application on behalf of the eligible entity(ies) listed on this application, that I have examined this application, that all of the information and responses in this application, including certifications, and forms submitted, all of which are part of this grant application, are material representations of fact and true and correct to the best of my knowledge, that the entity(ies) that is requesting grant funding pursuant to this application and any subgrantees and subcontractors will comply with the terms, conditions, purposes, and federal requirements of the grant program; that no kickbacks were paid to anyone; and that a false, fictitious, or fraudulent statements or claims on this application are grounds for denial or termination of a grant award, and/or possible punishment by a fine or imprisonment as provided in 18 U.S.C. §1001 and civil violations of the False Claims Act.

(ii) I certify that the entity(ies) I represent have and will comply with all applicable federal, state, and local laws, rules, regulations, ordinances, codes, orders and programmatic rules and requirements relating to the project. I acknowledge that failure to do so may result in rejection or deobligation of the grant or loan award. I acknowledge that failure to comply with all federal and program rules could result in civil or criminal prosecution by the appropriate law enforcement authorities.

(iii) I certify that the entity(ies) I represent has and will comply with all applicable administrative and federal statutory, regulatory, and policy requirements set forth in the DOC Pre-Award Notification, published in the Federal Register on February 11, 2008 (73 FR 7696), as amended; DOC Financial Assistance Standard Terms and Conditions (Mar. 8, 2009); DOC American Recovery and Reinvestment Act Award Terms (April 9, 2009); and any Special Award Terms and Conditions that are included by the Grants Officer in the award."

8/12/2009  
(Date)

Lewis Foster  
(Authorized Representative's Signature)

Lewis Foster  
Name:

IT Manager  
Title:

## List of Financial Assumptions for the Pro Forma Financial Statements (Attachments K, L, and M):

### Columbia County Community Broadband Network

1. Columbia County will establish the Columbia County Community Broadband Network (CCCBN) as a wholly owned unit of the County. It will be organized as a separately funded utility, similar to the current water utility.
2. The General Fund of the County will support the staff during the start-up period and will provide all necessary operating capital until the CCCBN becomes operational.
3. The match for the grant will be from County resources. It will not be a loan.
4. A separate account will be established to receive the BTOP funds and matching funds. It is assumed that all construction and engineering funds will be paid from this account. The assets resulting from this fund appear as "Plant in Service" in the Pro Forma documents.
5. It is assumed that at the end of Year 1, approximately \$10,774,500 of plant assets will be constructed and paid for by the separate BTOP fund.
6. The Five Year Pro Forma is intended to show the routine 5-year operation of the CCCBN. It does not detail all the cash flows and asset flows related to the separate construction accounts.
7. It is assumed that the CCCBN receives \$13,513,002 in grant funds and \$4,489,128 in matching (both cash and in-kind contributions).
8. The net cash provided by operations will be used to:
  - a. Expand the capabilities and services of the network
  - b. Provide outreach and subsidized service to anchor institutions and economically challenged population
  - c. Return funds to the county's general budget to cover the match.
9. All estimates of costs and revenue projections have been developed with the assistance of a local engineering firm experienced in telecommunications projects in the area, in order to insure more accurate projections.

# Balance Sheet

<b>Assets</b>	Historical		Forecast Period				
			Year 1	Year 2	Year 3	Year 4	Year 5
<i>Current Assets</i>							
Cash	\$ -	\$ -	\$ 11,050	\$ 24,840	\$ 465,175	\$ 365,485	\$ 293,295
Marketable Securities	\$ -	\$ -	\$ -	\$ -	\$ -	\$ -	\$ -
Accounts Receivable	\$ -	\$ -	\$ -	\$ -	\$ -	\$ -	\$ -
Notes Receivable	\$ -	\$ -	\$ -	\$ -	\$ -	\$ -	\$ -
Inventory	\$ -	\$ -	\$ -	\$ -	\$ -	\$ -	\$ -
Prepayments	\$ -	\$ -	\$ -	\$ -	\$ -	\$ -	\$ -
Other Current Assets	\$ -	\$ -	\$ -	\$ -	\$ -	\$ -	\$ -
<b>Total Current Assets</b>	\$ -	\$ -	\$ 11,050	\$ 24,840	\$ 465,175	\$ 365,485	\$ 293,295
<i>Non-Current Assets</i>							
Long-Term Investments	\$ -	\$ -	\$ -	\$ -	\$ -	\$ -	\$ -
Amortizable Asset (Net of Amortization)	\$ -	\$ -	\$ -	\$ -	\$ -	\$ -	\$ -
Plant in Service	\$ -	\$ -	\$ 10,774,500	\$ 13,184,500	\$ 13,184,500	\$ 13,184,500	\$ 13,184,500
Less: Accumulated Depreciation	\$ -	\$ -	\$ -	\$ 323,235	\$ 653,525	\$ 951,215	\$ 1,257,405
Net Plant	\$ -	\$ -	\$ -	\$ -	\$ -	\$ -	\$ -
Other	\$ -	\$ -	\$ -	\$ -	\$ -	\$ -	\$ -
<b>Total Non-Current Assets</b>	\$ -	\$ -	\$ 10,774,500	\$ 13,507,735	\$ 13,838,025	\$ 14,135,715	\$ 14,441,905
<b>Total Assets</b>	\$ -	\$ -	\$ 10,785,550	\$ 13,532,575	\$ 14,303,200	\$ 14,501,200	\$ 14,735,200
<b>Liabilities and Owners' Equity</b>							
<b>Liabilities</b>							
<i>Current Liabilities</i>							
Accounts Payable	\$ -	\$ -	\$ -	\$ -	\$ -	\$ -	\$ -
Notes Payable	\$ -	\$ -	\$ -	\$ -	\$ -	\$ -	\$ -
Current Portion - Total RUS Debt	\$ -	\$ -	\$ -	\$ -	\$ -	\$ -	\$ -
Current Portion - Other Debt	\$ -	\$ -	\$ -	\$ -	\$ -	\$ -	\$ -
Other Current Liabilities	\$ -	\$ -	\$ -	\$ -	\$ -	\$ -	\$ -
<b>Total Current Liabilities</b>	\$ -	\$ -	\$ -	\$ -	\$ -	\$ -	\$ -
<i>Long-Term Liabilities</i>							
Existing RUS Debt	\$ -	\$ -	\$ -	\$ -	\$ -	\$ -	\$ -
Proposed RUS Debt	\$ -	\$ -	\$ -	\$ -	\$ -	\$ -	\$ -
Existing non-RUS Debt	\$ -	\$ -	\$ -	\$ -	\$ -	\$ -	\$ -
<b>Total Long-Term Liabilities</b>	\$ -	\$ -	\$ -	\$ -	\$ -	\$ -	\$ -
<b>Total Liabilities</b>	\$ -	\$ -	\$ -	\$ -	\$ -	\$ -	\$ -
<b>Owner's Equity</b>							
Capital Stock	\$ -	\$ -	\$ -	\$ -	\$ -	\$ -	\$ -
Additional Paid-In Capital	\$ -	\$ -	\$ -	\$ -	\$ -	\$ -	\$ -
Patronage Capital Credits	\$ -	\$ -	\$ 10,774,500	\$ 13,507,735	\$ 13,838,025	\$ 14,135,715	\$ 14,441,905
Retained Earnings	\$ -	\$ -	\$ 11,050	\$ 348,075	\$ 1,118,700	\$ 1,316,700	\$ 1,550,700
<b>Total Equity</b>	\$ -	\$ -	\$ 10,785,550	\$ 13,855,810	\$ 14,956,725	\$ 15,452,415	\$ 15,992,605
<b>Total Liabilities and Owner's Equity</b>	\$ -	\$ -	\$ 10,785,550	\$ 13,855,810	\$ 14,956,725	\$ 15,452,415	\$ 15,992,605

# Income Statement

	Historical		Forecast Period									
			Year 1	Year 2	Year 3	Year 4	Year 5					
<b>Revenues</b>												
Network Services Revenues:												
Local Voice Service	\$	-	\$	-	\$	-	\$	-				
Broadband Data	\$	-	\$	36,000	\$	556,475	\$	1,411,500	\$	1,615,500	\$	1,849,500
Video Services	\$	-	\$	-	\$	-	\$	-	\$	-	\$	-
Network Access Service Revenues	\$	-	\$	-	\$	-	\$	-	\$	-	\$	-
Universal Service Fund	\$	-	\$	-	\$	-	\$	-	\$	-	\$	-
Toll Service/Long Distance Voice	\$	-	\$	-	\$	-	\$	-	\$	-	\$	-
Installation Revenues	\$	-	\$	-	\$	-	\$	-	\$	-	\$	-
Other Operating Revenues	\$	-	\$	-	\$	-	\$	-	\$	-	\$	-
Other Revenues	\$	-	\$	-	\$	-	\$	-	\$	-	\$	-
Uncollectible Revenues	\$	-	\$	-	\$	-	\$	-	\$	-	\$	-
<b>Total Revenues</b>	\$	-	\$	36,000	\$	556,475	\$	1,411,500	\$	1,615,500	\$	1,849,500
<b>Expenses</b>												
Backhaul	\$	-	\$	-	\$	44,000	\$	48,000	\$	48,000	\$	48,000
Network Maintenance/Monitoring	\$	-	\$	22,500	\$	120,000	\$	192,000	\$	192,000	\$	192,000
Utilities	\$	-	\$	450	\$	3,600	\$	3,600	\$	3,600	\$	3,600
Leasing	\$	-	\$	-	\$	-	\$	-	\$	-	\$	-
Sales/Marketing	\$	-	\$	-	\$	4,800	\$	6,000	\$	6,000	\$	6,000
Customer Care	\$	-	\$	-	\$	2,400	\$	6,000	\$	6,000	\$	6,000
Billing	\$	-	\$	-	\$	2,400	\$	6,000	\$	6,000	\$	6,000
Corporate G&A	\$	-	\$	1,000	\$	7,200	\$	7,200	\$	7,200	\$	7,200
Other Operating Expense	\$	-	\$	1,000	\$	24,000	\$	24,000	\$	30,000	\$	30,000
<b>Total</b>	\$	-	\$	24,950	\$	208,400	\$	292,800	\$	298,800	\$	298,800
<b>EBITDA</b>	\$	-	\$	11,050	\$	348,075	\$	1,118,700	\$	1,316,700	\$	1,550,700
Depreciation	\$	-	\$	-	\$	323,235	\$	653,525	\$	951,215	\$	1,257,405
Amortization	\$	-	\$	-	\$	-	\$	-	\$	-	\$	-
<b>Earnings Before Interest and Taxes</b>	\$	-	\$	11,050	\$	24,840	\$	465,175	\$	365,485	\$	293,295
Interest Expense - New RUS Debt	\$	-	\$	-	\$	-	\$	-	\$	-	\$	-
Interest Expense - Existing RUS Debt	\$	-	\$	-	\$	-	\$	-	\$	-	\$	-
Interest Expense - Other	\$	-	\$	-	\$	-	\$	-	\$	-	\$	-
<b>Income Before Taxes</b>	\$	-	\$	-	\$	-	\$	-	\$	-	\$	-
Property Tax	\$	-	\$	-	\$	-	\$	-	\$	-	\$	-
Income Taxes	\$	-	\$	-	\$	-	\$	-	\$	-	\$	-
<b>Net Income</b>	\$	-	\$	11,050	\$	24,840	\$	465,175	\$	365,485	\$	293,295

## Statement of Cash Flows

	Historical		Forecast Period				
			Year 1	Year 2	Year 3	Year 4	Year 5
<b>Beginning Cash</b>	\$ -	\$ -	\$ -	\$ 11,050	\$ 35,890	\$ 501,065	\$ 866,550
<b>CASH FLOWS FROM OPERATING ACTIVITIES:</b>							
Net Income	-	-	11,050	24,840	465,175	365,485	293,295
<i>Adjustments to Reconcile Net Income to Net Cash Provided by Operating Activities</i>							
Add: Depreciation	-	-	-	-	-	-	-
Add: Amortization	-	-	-	-	-	-	-
<i>Changes in Current Assets and Liabilities:</i>							
Marketable Securities	-	-	-	-	-	-	-
Accounts Receivable	-	-	-	-	-	-	-
Inventory	-	-	-	-	-	-	-
Prepayments	-	-	-	-	-	-	-
Other Current Assets	-	-	-	-	-	-	-
Accounts Payable	-	-	-	-	-	-	-
Other Current Liabilities	-	-	-	-	-	-	-
<b>Net Cash Provided (Used) by Operations</b>	<b>\$ -</b>	<b>\$ -</b>	<b>\$ 11,050</b>	<b>\$ 24,840</b>	<b>\$ 465,175</b>	<b>\$ 365,485</b>	<b>\$ 293,295</b>
<b>CASH FLOWS FROM FINANCING ACTIVITIES:</b>							
Notes Receivable	-	-	-	-	-	-	-
Notes Payable	-	-	-	-	-	-	-
Principal Payments	-	-	-	-	-	-	-
New Borrowing	-	-	-	-	-	-	-
Additional Paid-in Capital	-	-	-	-	-	-	-
Additions to Patronage Capital Credits	-	-	-	-	-	-	-
Payment of Dividends	-	-	-	-	-	-	-
<b>Net Cash Provided by Financing Activities</b>	<b>\$ -</b>	<b>\$ -</b>	<b>\$ -</b>	<b>\$ -</b>	<b>\$ -</b>	<b>\$ -</b>	<b>\$ -</b>
<b>CASH FLOWS FROM INVESTING ACTIVITIES:</b>							
Capital Expenditures	-	-	-	-	-	-	-
Amortizable Asset (Net of Amortization)	-	-	-	-	-	-	-
Long-Term Investments	-	-	-	-	-	-	-
<b>Net Cash Used by Investing Activities</b>	<b>\$ -</b>	<b>\$ -</b>	<b>\$ -</b>	<b>\$ -</b>	<b>\$ -</b>	<b>\$ -</b>	<b>\$ -</b>
<b>Net Increase (Decrease) in Cash</b>	<b>\$ -</b>	<b>\$ -</b>	<b>\$ -</b>	<b>\$ -</b>	<b>\$ -</b>	<b>\$ -</b>	<b>\$ -</b>
<b>Ending Cash</b>	<b>\$ -</b>	<b>\$ -</b>	<b>\$ 11,050</b>	<b>\$ 35,890</b>	<b>\$ 501,065</b>	<b>\$ 866,550</b>	<b>\$ 1,159,845</b>





**ATTACHMENT E – PROJECT PLAN (KEY PHASES AND MILESTONES TO DEMONSTRATE DEGREE OF COMPLETION)**

- Use the following table to list the major network build-out phases and milestones that can demonstrate that your entire project will be substantially complete by the end of Year 2 and fully complete by the end of Year 3. This is to be done at the aggregate level (combining all proposed funded service areas.)
- Indicate how the milestones listed below will demonstrate these completion objectives. The applicant should consider such project areas as: a) network design; b) securing all relevant licenses and agreements; c) site preparation; d) equipment procurement; e) inside plant deployment; f) outside plant deployment; g) equipment deployment; h) network testing; i) network complete and operational. The applicant may provide any other milestones that it believes showcase progress.
- Project inception (Year 0) starts at the date when the applicant receives notice that the project has been approved for funding.
- In the table, provide any information (e.g., facts, analysis) to: a) demonstrate the reasonableness of these milestones; b) substantiate the ability to reach the milestones by the quarters indicated.
- On a separate sheet, describe the key challenges, if any, to a timely completion of the project, including any applicable mitigation plans.

Time Period	Quarter	List All Relevant Milestones	Support for Reasonableness/Data Points
Year 0	-	<ul style="list-style-type: none"> <li>• Begin Tower Site/Land Acquisition</li> <li>• Begin Tower zoning/permitting</li> <li>• Begin Fiber Cable engineering/permitting</li> </ul>	<ul style="list-style-type: none"> <li>• Tower activities require longer lead time; begin as first phase of project</li> <li>• Cable engineering – route details, staking sheets, establish unit contract prices</li> </ul>
Year 1	Qtr. 1	<ul style="list-style-type: none"> <li>• Tower zoning/permitting ongoing</li> <li>• Fiber Cable engineering/permitting completed</li> <li>• Negotiate Fiber construction contracts</li> <li>• Begin initial fiber construction</li> <li>• Begin Library Computer Equipment installation</li> </ul>	<ul style="list-style-type: none"> <li>• Initial fiber engineering takes place in areas where initial cable construction will occur</li> </ul>
	Qtr. 2	<ul style="list-style-type: none"> <li>• Tower zoning/permitting completed</li> <li>• Tower RFPs issued</li> <li>• Fiber Cable construction ongoing</li> <li>• End Library Computer Equipment installation</li> </ul>	<ul style="list-style-type: none"> <li>• Fiber construction progress rate: 1 crew does 1 mile per week; plan 3-4 crews at a time</li> </ul>
	Qtr. 3	<ul style="list-style-type: none"> <li>• Fiber Cable construction ongoing</li> <li>• Tower RFP awarded / construction begins</li> <li>•</li> </ul>	<ul style="list-style-type: none"> <li>• Multiple tower crews</li> </ul>
	Qtr. 4	<ul style="list-style-type: none"> <li>• Tower Construction ongoing</li> <li>• Fiber Cable construction complete</li> <li>• Begin County Metro E installation</li> </ul>	<ul style="list-style-type: none"> <li>• Fiber completion allows Service Providers to connect to last mile serving areas and county systems to come on line</li> </ul>
	Qtr. 1	<ul style="list-style-type: none"> <li>• Tower Construction ongoing</li> <li>• County Metro E equipment install ongoing</li> </ul>	<ul style="list-style-type: none"> <li>• Metro E install – 19 weeks</li> </ul>



Year 2		<ul style="list-style-type: none"> <li>• Begin Traffic System equipment install</li> </ul>	
	Qtr. 2	<ul style="list-style-type: none"> <li>• Tower construction/testing complete</li> <li>• County Metro E equipment install complete</li> <li>• Traffic System equipment install ongoing</li> </ul>	<ul style="list-style-type: none"> <li>• Traffic system install – 11 weeks</li> </ul>
	Qtr. 3	<ul style="list-style-type: none"> <li>• Traffic system equipment install complete</li> <li>• Wireless Site Surveys (Wi-Fi)</li> <li>• Begin School Board Equipment Install</li> <li>• Begin Grovetown/Harlem/FD Equipment Install</li> </ul>	<ul style="list-style-type: none"> <li>• Wi-Fi system install – 16 weeks</li> </ul>
	Qtr. 4	<ul style="list-style-type: none"> <li>• Wi-Fi Network Installation ongoing</li> <li>• School Board Equipment Install Ongoing</li> <li>• Grovetown/Harlem/FD Equipment Install Ongoing</li> <li>• Begin Computer Center Equipment Install</li> </ul>	<ul style="list-style-type: none"> <li>• School Board Equipment install – 12 weeks</li> </ul>
Year 3	Qtr. 1	<ul style="list-style-type: none"> <li>• Wi-Fi Network Installation Complete</li> <li>• School Board Equipment Install Complete</li> <li>• Grovetown/Harlem/FD Equipment Install ongoing</li> <li>• Computer Center Equipment install complete</li> </ul>	<ul style="list-style-type: none"> <li>• Computer Center Equipment install – 9 weeks</li> </ul>
	Qtr. 2	<ul style="list-style-type: none"> <li>• Grovetown/Harlem/FD Equipment Install Complete</li> </ul>	<ul style="list-style-type: none"> <li>• Georgetown/Harlem/FD equipment install – 18 weeks</li> </ul>
	Qtr. 3	<ul style="list-style-type: none"> <li>•</li> </ul>	<ul style="list-style-type: none"> <li>•</li> </ul>
	Qtr. 4	<ul style="list-style-type: none"> <li>•</li> </ul>	<ul style="list-style-type: none"> <li>•</li> </ul>













### **Possible Challenges to Timely Completion of the Project**

- Availability of Fiber Optic cable and other materials
- Delays in permitting for fiber and tower construction
- Construction delays resulting from unpredictable terrain and/or weather

### **Possible Mitigation Plans:**

- Plan to subdivide the 200 miles of fiber optic construction into four (4) regional projects, in order to expedite construction in the areas with the most immediate demand
- Establish unit contract costs to enable immediate negotiation with contractors and start of construction



**Network Design and Implementation Plan Certification (to be complete for projects requesting more than \$1 million in federal assistance)**

**U.S. Department of Agriculture and U.S. Department of Commerce  
BIP and BTOP Program**

We the undersigned, certify that the proposed broadband system will work as described in the System Design and Network Diagram sections, and can deliver the proposed services outlined in the Service Offerings Section. Moreover, the system, as designed, can meet the proposed build-out timeframe based on the resources designated in Project Viability Section, and will be substantially complete in two years, and complete within three years.

8-12-09

(Date)

Lewis Foster

(Authorized Representative's Signature)

Lewis Foster

Name:

IT Manager

Title:

08-12-2009

(Date)

William M. Martin

(Certifying Engineer's Signature)

William M. Martin

Name:

Senior Project Manager

Title:



LAW OFFICES  
**HULL, TOWILL, NORMAN, BARRETT & SALLEY**

A PROFESSIONAL CORPORATION

POST OFFICE BOX 1564  
AUGUSTA, GEORGIA 30903-1564

OFFICE

SUNTRUST BANK BUILDING  
801 BROAD STREET, SEVENTH FLOOR  
AUGUSTA, GEORGIA 30901

TELEPHONE (706) 722-4481  
FACSIMILE (706) 722-9779  
www.hullfirm.com

DAVIS A. DUNAWAY  
J. CHRISTOPHER DRIVER  
ALANA KYRIAKAKIS<sup>1</sup>  
CHRISTOPHER A. COSPER<sup>1</sup>  
SUSAN M. CLAPP<sup>4</sup>  
MICHAEL E. FOWLER, JR.<sup>7</sup>  
PAUL K. SIMONS, JR.<sup>1</sup>  
CHRISTINE M. SHAFFER<sup>2</sup>

OF COUNSEL

WM. HALE BARRETT  
N. SHANNON GENTRY LANIER  
JAMES K. STUCKO<sup>8</sup>

<sup>1</sup>(ALSO SC)  
<sup>2</sup>(SC ONLY)  
<sup>3</sup>(ALSO FL AND SC)  
<sup>4</sup>(ALSO NC)  
<sup>5</sup>(ALSO TN AND SC)  
<sup>6</sup>(ALSO IL)  
<sup>7</sup>(ALSO SC AND AL)  
<sup>8</sup>(ALSO SC AND NY)

LAWTON JORDAN, JR.  
PATRICK J. RICE  
DOUGLAS D. BATCHELOR, JR.<sup>3</sup>  
DAVID E. HUDSON  
NEAL W. DICKERT<sup>1</sup>  
WILLIAM H. TUCKER<sup>2</sup>  
WILLIAM F. HAMMOND  
MARK S. BURGREN<sup>1</sup>  
GEORGE R. HALL<sup>1</sup>  
JAMES B. ELLINGTON  
F. MICHAEL TAYLOR<sup>1</sup>  
WILLIAM J. KEOGH, III  
EDWARD J. TARVER  
R. E. HANNA III<sup>1</sup>  
JAMES M. HOLLY<sup>1</sup>  
TIMOTHY E. MOSES<sup>1</sup>  
TARA RICE SIMKINS  
JAMES V. PAINTER<sup>8</sup>  
DARREN G. MEADOWS  
JAMES S.V. WESTON  
JOHN B. WEST<sup>8</sup>  
THOMAS L. CATHEY<sup>4</sup>

August 12, 2009

Administrator  
Rural Utilities Service  
U.S. Department of Agriculture  
Washington, D.C. 20250-1500

Assistant Secretary  
National Telecommunications and Information Administration  
U.S. Department of Commerce  
Washington, D.C. 20230

Re: Application by Columbia County, Georgia for Broadband Technology  
Opportunities Program Grant

Dear Sir:

We are general counsel for Columbia County, Georgia, (the "Applicant"). In such capacity, we are acting as counsel to the Applicant in connection with its ability to apply to the Broadband Technology Opportunities Program and in the review of the grant agreement, as referenced in the Notice of Funds Availability.

We are of the opinion that:

(a) the Applicant is a duly organized and existing county and political subdivision, under the laws of the State of Georgia.

(b) the Applicant has the legal power: (1) to execute and deliver the grant agreement and (2) to perform all acts required to be done by it under said agreement.

(c) no legal proceedings have been instituted or are pending against the Applicant, the outcome of which would adversely affect the Applicant's ability to perform the duties under the grant

agreement, and there are no judgments against the Applicant which would adversely affect the Applicant's ability to perform the duties under the grant agreement. The Applicant is named as a defendant in the case of Marshall Square, LLC v. Columbia County, Georgia, et al., pending in the Superior Court of Columbia County, wherein the plaintiff is seeking \$57,000,000.00 in damages. Of the claimed damages, \$40,000,000.00 is for punitive damages which cannot be awarded against a county under Georgia law. The lawsuit seeks damages for the failure of the Board of Commissioners to re-zone property owned by the plaintiff as requested by the owner. The Applicant is vigorously defending the case and expects to have a favorable outcome.

Very truly yours,

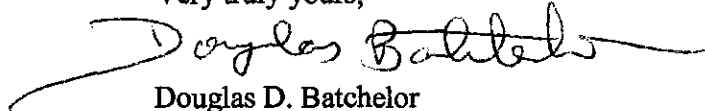
A handwritten signature in cursive script that reads "Douglas D. Batchelor". The signature is written in black ink and is positioned above the typed name.

Douglas D. Batchelor  
County Attorney for  
Columbia County, Georgia







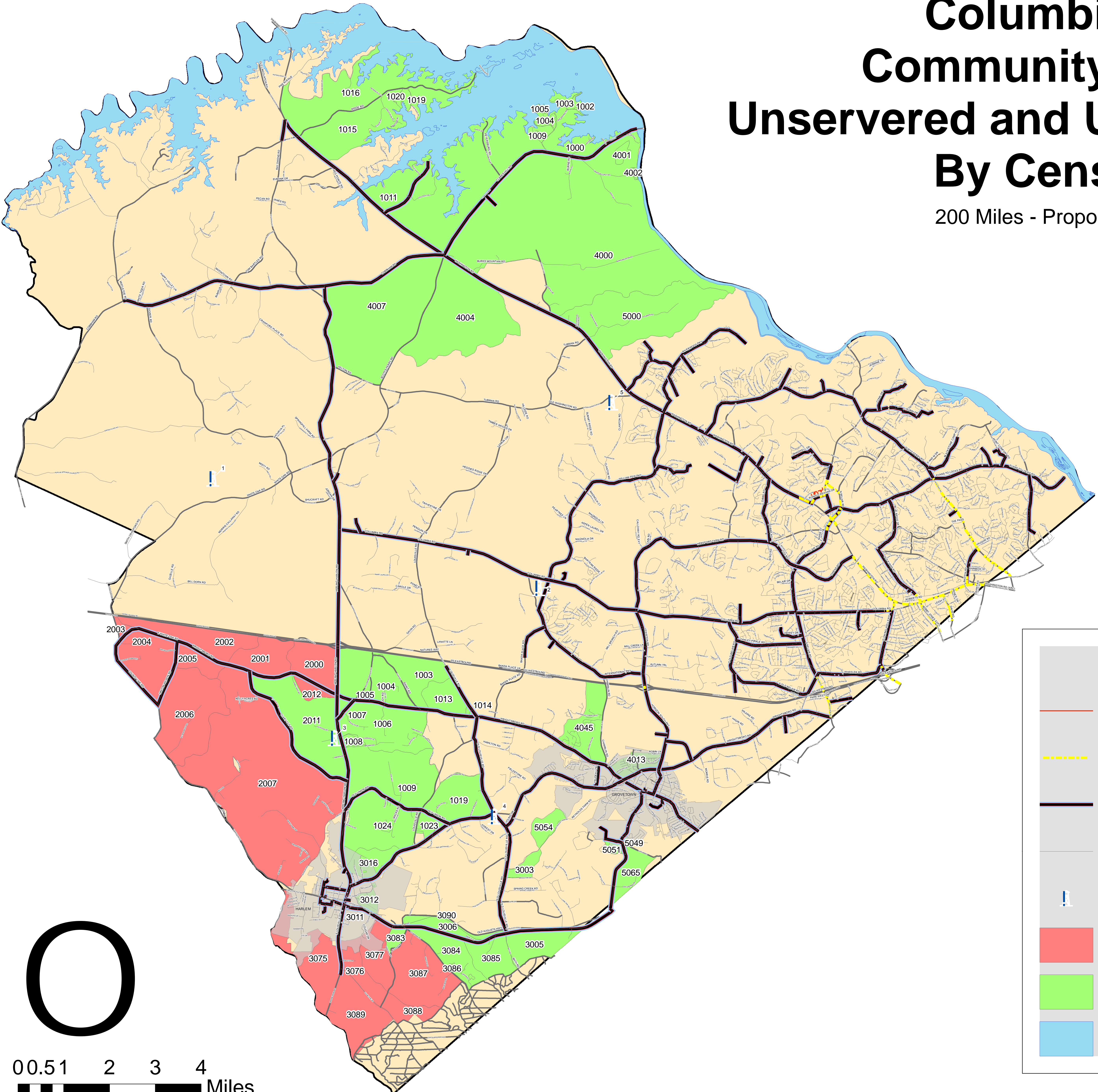

# Columbia County Community Broadband Unservered and Underserved Areas By Census Block

200 Miles - Proposed Broadband Length

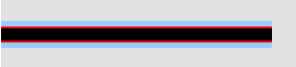
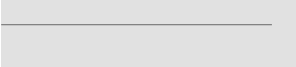

**Legend**

-  Existing Local Fiber
-  Existing Traffic Fiber
-  Master Plan - Broadband
-  Roads
-  Proposed Tower (5)
-  Unserved Census Block (15)
-  Underserved Census Block (54)
-  Large Waterbody

Census block boundaries are from the year 2000.

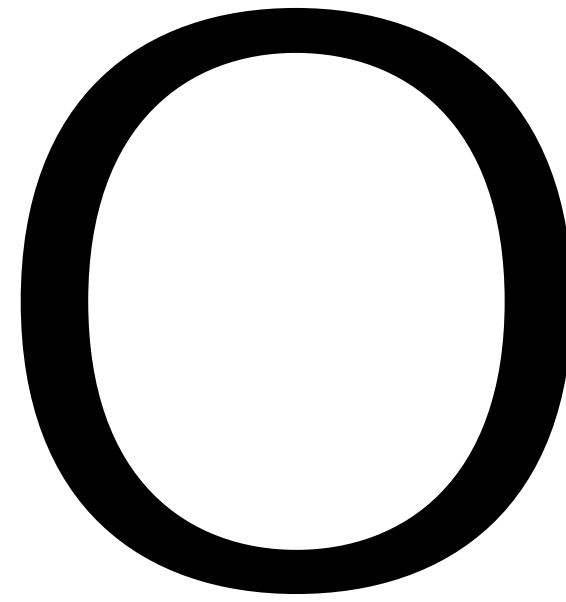

0 0.5 1 2 3 4  
Miles



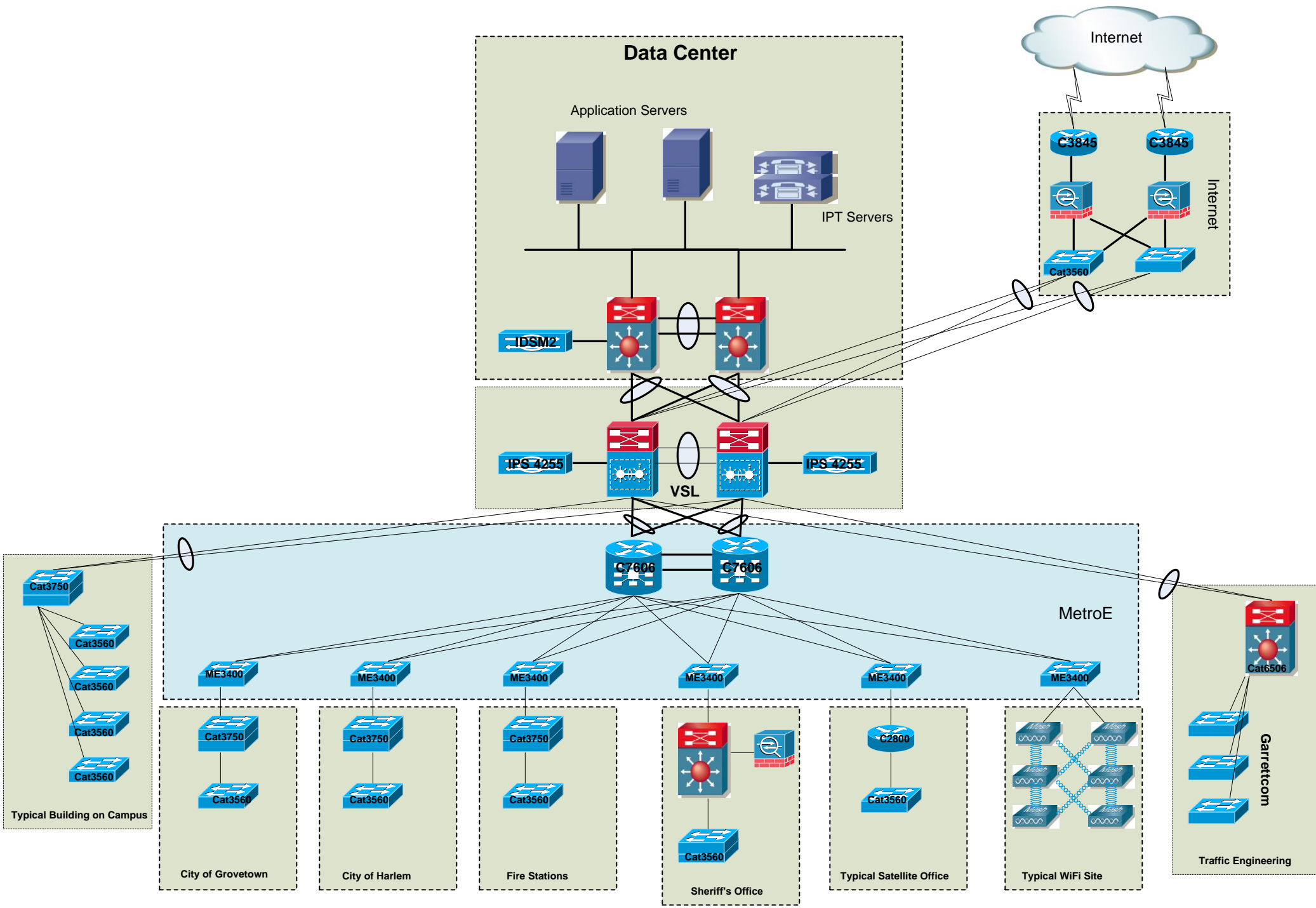

**Data Center**

Application Servers

IPT Servers

IDS M2

VSL

IPS 4255

IPS 4255

**MetroE**

C7606

C7606

ME3400

ME3400

ME3400

ME3400

ME3400

ME3400

Typical Building on Campus

City of Grovetown

City of Harlem

Fire Stations

Sheriff's Office

Typical Satellite Office

Typical WiFi Site

Traffic Engineering

Internet

C3845

C3845

Internet

Cat3560

Cat3560

Garretcom

Cat6506

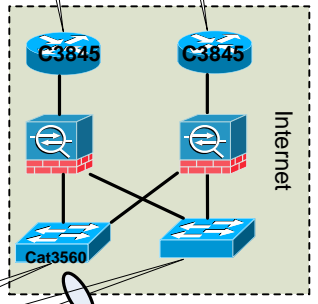
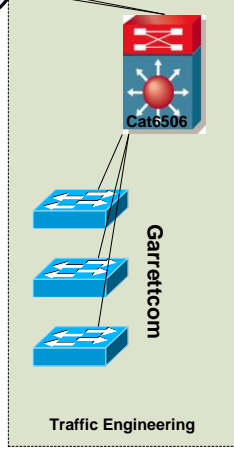
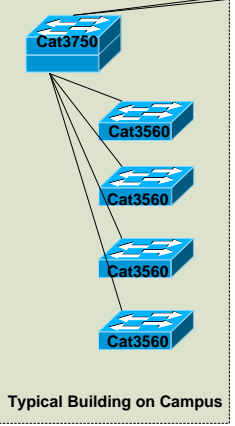
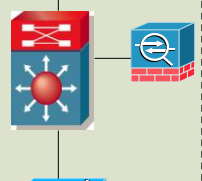
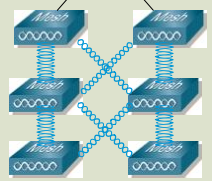

WS-X6748-GE-TX	WS-X6748-GE-TX
WS-SVC-IDS-M-2	WS-X6348-RJ-45
WS-SUP720-3B	WS-SUP720-3B
WS-X6408A-GBIC	WS-X6416-GBIC
WS-X6704-10GE	WS-X6704-10GE

WS-SVC-NAM-2	
VS-S720-10G-3C	VS-S720-10G-3C
WS-X6748-GE-TX	WS-X6748-GE-TX
WS-X6724-SFP	WS-X6724-SFP
WS-X6708-10G-3C	WS-X6708-10G-3C

WS-X6704-10GE	WS-X6704-10GE
RSP720-3C-GE	RSP720-3C-GE
7600-ES+20G3C	7600-ES+20G3C

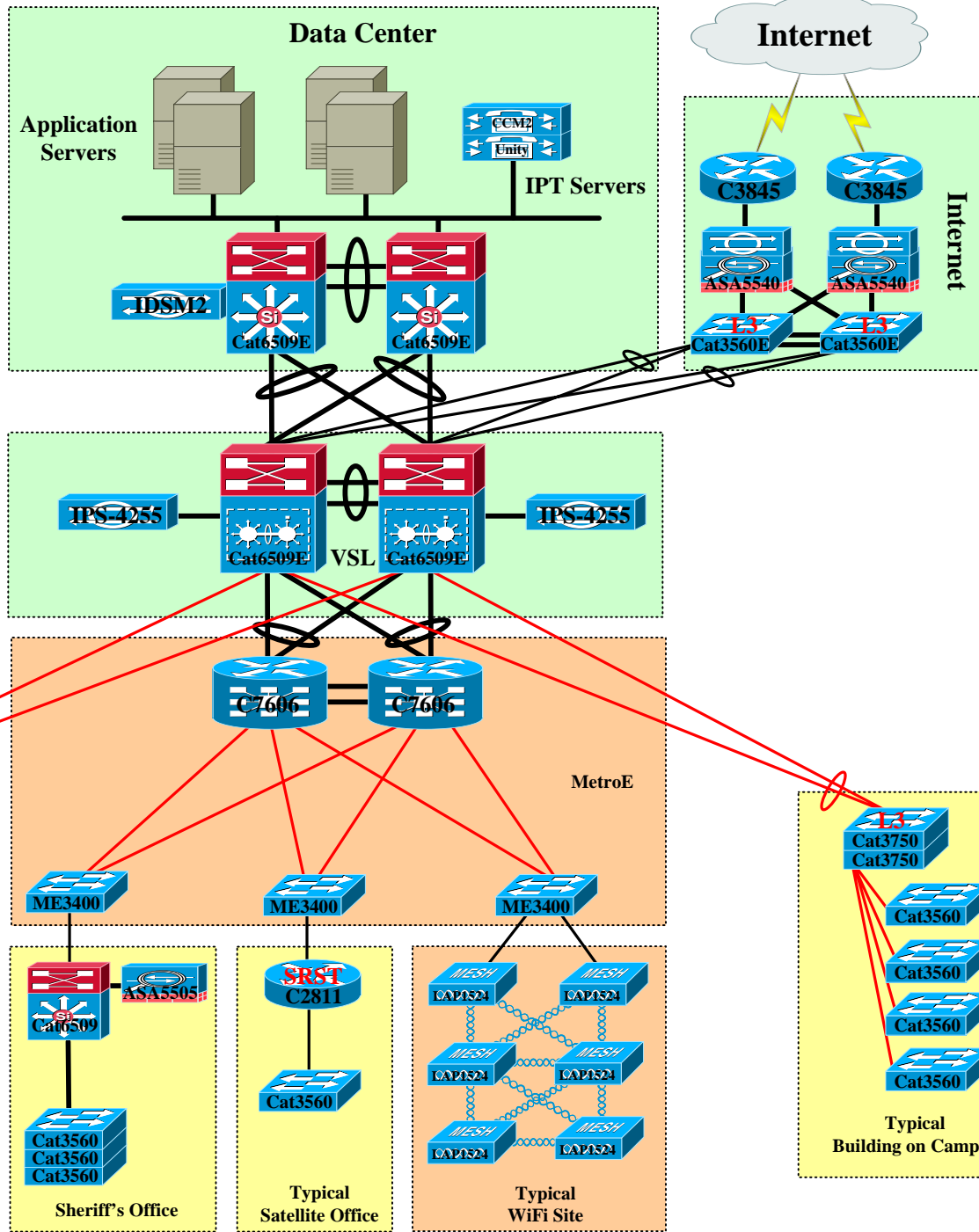
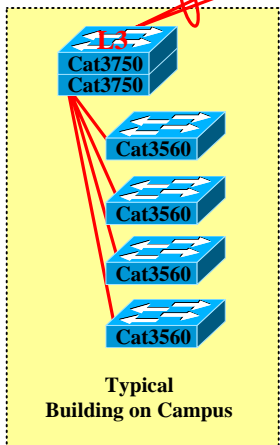

## Proposed ColumbiaCBC Network Upgrade with MetroE and WiFi Overview

Prepared by Charles Lan of Logicalis

## **Attachment B – Proposed Middle Mile Service Offerings**

Please complete the table below describing the service offerings that will be available indicating the bandwidth packages, the distance band (length of the network section) or point-to-point (geographical end points) of the specific package, the minimum peak load bandwidth that is available on the route, and the monthly or yearly pricing for the services. The chart may be adapted to adequately describe the service offerings of the project as long as the information described is included. If different packages will be available based on the area that will be receiving the benefits, then separate charts should be developed indicating which are the services for each area.

**Note:** The following narrative is the “**description of how you will make it available to the broadest group of users (e.g. libraries, hospitals, educational institutions, public safety, etc.) and if there are any restrictions on use**” which is required as part of Question 20, “Service Offerings for Middle Mile Projects.” The completed Attachment B follows the narrative.

*The Middle Mile Service Offerings shown in Attachment B represent the basis on which Columbia County will charge third-party service providers to allow them to interconnect to the citizens of the county. The goal of the project is one of complete openness to any and all potential service providers, so as a result there will be no restrictions on use of the facilities. Any legitimate service provider wishing to lease facilities will be allowed and encouraged to do so. The County has already received a commitment from Knology to enter into a fiber lease to serve Harlem and Grovetown.*

*In terms of hospitals, libraries, educational institutions, public safety organizations, etc., the county has partnered with all such organizations from the beginning of the project. All such facilities in the County are contained in the anchor institutions which will be connected to the project as initial end users of the county-wide network. For more details concerning these institutions and how they will be made part of the project, including approximately 20 letters of support from all such organizations, please see Question 41, “Government and Key Partnerships”, as well as Question 18, “Middle Mile Benefits”.*

Service Offering	Distance Band or Point to Point	Minimum Peak Load Network Bandwidth Capacity (Mbps)	Monthly/ <del>Yearly</del> Pricing (\$)	Other
Dark Fiber Leasing	Distance based	1 Gbps	\$125 per fiber pair per mile (per month)	<= 10 miles of fiber
	Distance based	1 Gbps	\$100 per fiber pair per mile (per month)	10-75 miles of fiber
	Distance based	1 Gbps	\$75 per fiber pair per mile (per month)	75-150 miles of fiber
	Distance based	1 Gbps	\$50 per fiber pair per mile (per month)	>= 150 miles of fiber
Tower attachments	Distance based	n/a	\$1 per linear foot of height, per month	
Colocation Space	n/a	n/a	\$125 per 5 rack spaces per month	For rack space in existing cabinet
	n/a	n/a	\$50 per square foot of floor space per month	For floor space in tower hut



## ATTACHMENT C – COMPETITOR TABLE – LAST MILE

**Existing Last Mile Broadband Service Providers and Services Offered:** Please complete a table describing the competing last mile providers’ broadband service offerings being advertised in each proposed funded service area (BIP applicants should complete this table for each census designated community within the proposed funded service area) . For each competitor, explain the following: a) technology; b) service tiers; c) advertised speeds for residential and business; d) pricing. Include any other comments to explain your findings, if necessary.

**Note: The Downstream Speeds and Pricing shown in the table below are taken from the national service providers’ websites. These speeds are not specifically advertised in Columbia County, nor are they available in all parts of Columbia County. In fact the service providers shown below do not offer any specific advertising targeted specifically at Columbia County. Furthermore the providers offer services only in certain portions of the service areas named in the table. For example it should not be inferred from the table that all of the Grovetown and Harlem areas can receive broadband services up to 5, 6, or 10 Mbps, even if some residents of the city limits may be able to do so.**

<Applicant Service Area Name> <b>Columbia County Georgia</b>								
Service Area	Last Mile Services Provider	Technology Platform	Service Tier	Advertised Residential Offering		Advertised Business Offering		Other Comments
				Downstream Speed (Mbps)	Price	Downstream Speed (Mbps)	Price	
<b>Grovetown &amp; Harlem (areas south of I-20)</b>	<b>Charter Cable</b>	Coax / cable modems	Entry Level Plan	Up to 1Mbps	19.99	Up to 7Mbps	70.00	
			Highest Speed Plan	Up to 10Mbps	64.99	Up to 20Mbps	235.00	
			Other Plans (e.g., Mid-Tier Plan)	Up to 5Mbps	54.99	Up to 8Mbps	120.00	
	<b>AT&amp;T</b>	Twisted pair / DSL	Entry Level Plan	Up to 768Kbps	19.95	Up to 768Kbps	26.95	
			Highest Speed Plan	Up to 6Mbps	42.95	Up to 6Mbps	59.95	
			Other Plans (e.g., Mid-Tier Plan)	Up to 3Mbps	37.95	Up to 3Mbps	49.95	
<b>Appling / Wildwood / Patriots Park</b>	<b>Comcast</b>	Coax / cable modems	Entry Level Plan	Up to 1Mbps	24.95	Up to 6Mbps	59.95	
			Highest Speed Plan	Up to 16Mbps	52.95	Up to 16Mbps	89.95	
			Other Plans (e.g., Mid-Tier Plan)	Up to 12Mbps	42.95			
	<b>AT&amp;T</b>	Twisted pair / DSL	Entry Level Plan	Up to 768Kbps	19.95	Up to 768Kbps	26.95	
			Highest Speed Plan	Up to 6Mbps	42.95	Up to 6Mbps	59.95	
			Other Plans (e.g., Mid-Tier Plan)	Up to 3Mbps	37.95	Up to 3Mbps	49.95	

<Applicant Service Area Name> <b>Columbia County Georgia</b>								
Service Area	Last Mile Services Provider	Technology Platform	Service Tier	Advertised Residential Offering		Advertised Business Offering		Other Comments
				Downstream Speed (Mbps)	Price	Downstream Speed (Mbps)	Price	
<b>Evans</b>	<b>Comcast Cable</b>	Coax / cable modems	Entry Level Plan	Up to 1Mbps	24.95	Up to 6Mbps	59.95	
			Highest Speed Plan	Up to 16Mbps	52.95	Up to 16Mbps	89.95	
			Other Plans (e.g., Mid-Tier Plan)	Up to 12Mbps	42.95			
	<b>AT&amp;T</b>	Twisted pair / DSL	Entry Level Plan	Up to 768Kbps	19.95	Up to 768Kbps	26.95	
			Highest Speed Plan	Up to 6Mbps	42.95	Up to 6Mbps	59.95	
			Other Plans (e.g., Mid-Tier Plan)	Up to 3Mbps	37.95	Up to 3Mbps	49.95	
<b>Evans</b>	<b>Knology</b>	HFC / cable modems	Entry Level Plan			Up to 15Mbps	Contact Rep	Hybrid Fiber
			Highest Speed Plan	Up to 6Mbps	61.95	Up to 1Gbps	Contact Rep	Res w Modem, Bus Pure Fiber
			Other Plans (e.g., Mid-Tier Plan)					

## ATTACHMENT C – COMPETITOR TABLE – MIDDLE MILE

**Existing Middle Mile Broadband Service Providers and Services Offered:** Please complete a table describing the competing middle mile providers’ broadband service offerings being advertised in the last mile service areas associated with the proposed middle mile project. **For BIP**, please provide this information for each census designated community within each last mile service area. For each competitor, explain the following: a) technology; b) service tiers; c) point-to-point of the competitor’s service offering; d) speed; and e) pricing. Include any other comments to explain your findings if necessary.

<Applicant Service Area Name>							
Service Area	Middle Mile Services Provider	Technology Platform	Service Tier	Point-to-Point	Minimum Peak Load Network Bandwidth Capacity	Pricing	Other Comments
<b>Service Area 1/ Census community 1</b>	<b>Provider A – n/a</b>		Entry Level Plan				There are currently no middle-mile competitors in Columbia County – only last mile providers. This information has been verified through the Georgia Public Service Commission
			Highest Speed Plan				
			Other Plans (e.g., Mid-Tier Plan)				
	<b>Provider B – n/a</b>		Entry Level Plan				
			Highest Speed Plan				
			Other Plans (e.g., Mid-Tier Plan)				
<b>Service Area 2/ Census community 2</b>	<b>Provider A – n/a</b>		Entry Level Plan				
			Highest Speed Plan				
			Other Plans (e.g., Mid-Tier Plan)				
	<b>Provider B – n/a</b>		Entry Level Plan				
			Highest Speed Plan				
			Other Plans (e.g., Mid-Tier Plan)				

**DETAIL OF PROJECT COSTS**

**PLEASE COMPLETE THE TABLE BELOW FOR THE DIFFERENT CATEGORIES OF EQUIPMENT THAT WILL BE REQUIRED FOR COMPLETING THE PROJECT. EACH CATEGORY SHOULD BE BROKENDOWN TO THE APPROPRIATE LEVEL FOR IDENTIFYING UNIT COST**

SERVICE AREA or COMMON NETWORK FACILITIES:		Eligibility (Yes/No)	Unit Cost	No. of Units	Total Cost	Support of Reasonableness
<b>NETWORK &amp; ACCESS EQUIPMENT</b>						
<b>Switching</b>	Cisco ME3400G-2CS	Yes	\$5,384.70	26	\$140,002	County Contract 38% Discount
	Cisco 3560-24PS	Yes	\$2,352.90	15	\$35,294	County Contract 38% Discount
	Cisco 3560E-24-TD	Yes	\$7,173.40	2	\$14,347	County Contract 38% Discount
	Cisco 3560-8PC-S	Yes	\$864.90	16	\$13,838	County Contract 38% Discount
	Cisco 3750G	Yes	\$4,426.80	6	\$26,561	County Contract 38% Discount
	Cisco 3750V2	Yes	\$5,229.70	4	\$20,919	County Contract 38% Discount
	Cisco 3560V2-48PS	Yes	\$4,026.90	2	\$8,054	County Contract 38% Discount
	Cisco 3560-12PC	Yes	\$1,236.90	4	\$4,948	County Contract 38% Discount
	Cisco 6506E	Yes	\$37,817.50	1	\$37,818	County Contract 38% Discount
	GarrettCom 6K32FC	Yes	\$2,440.00	58	\$141,520	County Contract 38% Discount
	Board of Ed – Cisco Network Equip	Yes	\$930,000.00	1	\$930,000	In-kind – part of matching funds
<b>Routing</b>	Cisco 7206	Yes	\$120,416.40	2	\$240,833	County Contract 38% Discount
	Cisco 7201	Yes	\$16,392.80	2	\$32,786	County Contract 38% Discount
<b>Transport</b>	WCS-PLUS-100	Yes	\$6,134.90	1	\$6,135	County Contract 38% Discount
	10Gig modules VSS	Yes	\$26,691.00	2	\$53,382	County Contract 38% Discount
	10GIG modules Server	Yes	\$14,089.50	2	\$28,179	County Contract 38% Discount
<b>Access</b>	AP1524PS-A-K9	Yes	\$4,645.66	66	\$306,614	County Contract 38% Discount
	4499 WLAN Controller	Yes	\$21,696.90	2	\$43,394	County Contract 38% Discount
<b>Other</b>	1520 Pole Mount Kit	Yes	\$79.98	66	\$5,279	County Contract 38% Discount
	1520 Power Injector and Tap	Yes	\$272.35	66	\$17,975	County Contract 38% Discount
	WCS Software UPGR	Yes	\$1,761.31	1	\$1,761	County Contract 38% Discount
	GLC-LH-SM Transceivers	Yes	\$616.90	100	\$61,690	County Contract 38% Discount
<b>OUTSIDE PLANT</b>						
<b>Cables</b>	Fiber Cable – installed	Yes	\$53,873	200	\$10,774,500	Per mile cost from Engg Firm

**DETAIL OF PROJECT COSTS**

						(includes conduits, ducts, pole attachments, and contingency)
<b>Conduits</b>						Included in per mile cost above
<b>Ducts</b>						Included in per mile cost above
<b>Poles</b>						Included in per mile cost above
<b>Towers</b>	300' self support towers	Yes	\$397,000	5	\$1,985,000	Per site cost from Engg Firm (includes all site work, bldg)
<b>Repeaters</b>						
<b>Other</b>						
<b>SERVICE AREA or COMMON NETWORK FACILITIES:</b>		<b>Eligibility (Yes/No)</b>	<b>Unit Cost</b>	<b>No. of Units</b>	<b>Total Cost</b>	<b>Support of Reasonableness</b>
<b>BUILDINGS</b>						
<b>New Construction</b>						
<b>Pre-Fab Huts</b>						
<b>Improvements &amp; Renovation</b>						
<b>Other</b>	Electrical Installation	Yes	\$8,000	1	\$8,000	In-kind – part of matching funds
<b>CUSTOMER PREMISE EQUIPMENT</b>						
<b>Modems</b>						
<b>Set Top Boxes</b>						

**DETAIL OF PROJECT COSTS**

<b>Inside Wiring</b>	Fire Stations	Yes	\$5,000	1	\$5,000	Multiple vendor quotes
	City Buildings	Yes	\$5,000	1	\$5,000	Multiple vendor quotes
	Park Buildings	Yes	\$5,000	1	\$5,000	Multiple vendor quotes
<b>Other</b>						
<b>BILLING SUPPORT AND OPERATIONS SUPPORT SYSTEMS</b>						
<b>Billing Support Systems</b>	General Billing Software	Yes	\$10,000	1	\$10,000	In-kind – part of matching funds
<b>Customer Care Systems</b>	Web Site	Yes	\$2,500	1	\$2,500	In-kind – part of matching funds
	Public Training Classes (Lib/Sr Ctr)	Yes	\$300	100	\$30,000	In-kind – part of matching funds
	City of Grovetown Training	Yes	\$300	50	\$15,000	In-kind – part of matching funds
	City of Harlem Training	Yes	\$300	50	\$15,000	In-kind – part of matching funds
	Community Connections	Yes	\$300	50	\$15,000	In-kind – part of matching funds
<b>Other Support</b>	Microsoft Office Professional	Yes	\$200	135	\$27,000	In-kind – part of matching funds
	Network Management Software	Yes	\$10,000	1	\$10,000	In-kind – part of matching funds
	Security Monitoring System	Yes	\$85,000	1	\$85,000	In-kind – part of matching funds
	Personal Health Care Sftwe (MCG)	Yes	\$142,591	1	\$142,591	In-kind – part of matching funds
	INSYNC Traffic Control System	Yes	\$42,520	12	\$510,240	In-kind – part of matching funds
<b>SERVICE AREA or COMMON NETWORK FACILITIES:</b>		Eligibility (Yes/No)	Unit Cost	No. of Units	Total Cost	Support of Reasonableness
<b>OPERATING EQUIPMENT</b>						
<b>Vehicles</b>						
<b>Office Equipment/ Furniture</b>						
<b>Other</b>						
<b>PROFESSIONAL SERVICES</b>						
<b>Engineering Design</b>	Outside Plant / Tower Engineering	Yes	\$538,186	1	\$538,186	Estimated cost from Engg Firm
<b>Project Management</b>	PM for inside plant and outside plant	Yes	\$1,077,989	1	\$1,077,989	Estimated cost from Engg Firm
	County Staff	Yes	\$232,402	1	\$232,402	In-kind – part of matching funds

**DETAIL OF PROJECT COSTS**

<b>Consulting</b>	Metro E, Network Upgrade, WiFi	Yes	\$187,50	440	\$82,500	Vendor Quotes
<b>Other</b>	Travel Expenses: Logicallis	Yes	\$17,500	1	\$17,500	Vendor Quotes
	Installation Network Eq	Yes	\$47,157	1	\$47,157	In-kind – part of matching funds
	Install Computers/Printers	Yes	\$13,987	1	\$13,987	In-kind – part of matching funds
	Financial Services	Yes	\$15,000	1	\$15,000	In-kind – part of matching funds
	County Mapping	Yes	\$2,000	1	\$2,000	In-kind – part of matching funds
	Installation Services BOE	Yes	\$30,000	1	\$30,000	In-kind – part of matching funds
<b>TESTING</b>						
<b>Network Elements</b>						
<b>IT System Elements</b>						
<b>User Devices</b>	Desktop Computer/Monitor	Yes	\$690	31	\$21,390	Vendor Quotes
	Laptops	Yes	\$774	60	\$46,440	Vendor Quotes
	Laptops Used	Yes	\$150	5	\$750	In-kind – part of matching funds
	Desktop Computer/Monitor(Used)	Yes	\$250	40	\$10,000	In-kind – part of matching funds
	Printers	Yes	\$250	4	\$1,000	Vendor Quotes
<b>Test Generators</b>						
<b>Lab Furnishings</b>	Euchee Creek Furniture	Yes	\$3072	1	\$3,072	Vendor Quotes
	Harlem Furniture	Yes	\$4,100	1	\$4,100	Vendor Quotes
<b>Servers/ Computers</b>						
<b>OTHER UPFRONT COSTS</b>						
<b>Site Preparation</b>						
<b>Other</b>	Land for Towers (Appling/GPS)	Yes	\$5,000	2	\$10,000	In-kind – part of matching funds
	Application Expenses	Yes	\$30,000	1	\$30,000	In-kind – part of matching funds
	Employee Travel Expense	Yes	\$2,500	1	\$2,500	In-kind – part of matching funds



## COLUMBIA COUNTY SCHOOL SYSTEM

4781 Hereford Farm Road  
Evans, Georgia 30809  
(706) 541-0650  
[www.ccbos.net](http://www.ccbos.net)

**Charles R. Nagle**  
Superintendent of Schools

**Sandra Carraway**  
Deputy Superintendent of Schools

August 14, 2009

**BOARD OF EDUCATION**  
Regina N. Buccafusco, Chairman  
Micheal N. Sleeper, Vice-Chairman  
Mildred R. Blackburn  
Wayne Bridges  
Roxanne Whitaker

Lewis Foster, IT Manager  
Office of Information Technology  
Columbia County Government  
Evans, Georgia 30809

Dear Mr. Foster:

The Columbia County government's technology department has applied for a grant to support the distribution of a fiber optic plant throughout Columbia County in order to serve a multitude of low and lesser served areas of the community. The Columbia County School System has been included throughout the planning process, with the thought that this updated fiber plant could enhance the school system's aging fiber plant that we currently lease and, therefore, help provide improved services to the children within our system.

Therefore, while many aspects of any agreement between the Columbia County Government and the school system still need to be reviewed and established, it is our intent to become an anchor tenant. This commitment is based upon what we currently pay for fiber connectivity between the schools and other non-instructional school system facilities.

Further, please be aware that this letter of intent is contingent upon the future negotiated contracts between the two entities described herein and should in no way be considered a binding letter of agreement to participate in the aforementioned fiber distribution plant project. It does, however, serve to inform necessary parties of our desire to participate as long as the rates, fiber counts, and future negotiations are in the best interest of the school system.

Questions and/or concerns regarding this correspondence should be directed to James Van Meter, Director of Technology, Columbia County School System (706-541-2721).

Sincerely,

A handwritten signature in black ink, appearing to read "Charles R. Nagle".

Charles R. Nagle, Superintendent  
Columbia County School System



Harold (Hal) H. Scott  
Vice President, Information Systems  
Chief Information Officer



July 22, 2009

Mr. Lewis Foster  
Columbia County Government Center  
PO Box 498  
630 Ronald Regan Drive  
Evans, GA 30809

Dear Mr. Foster:

I am writing this letter to show our support for the establishment of a regional broadband information exchange for Columbia County. We believe the establishment of such a network capability would substantially improve communication among and between health care providers in the region.

Such a network could be used to transmit vital clinical data that could not only improve treatment for the citizens that would access the health systems within the region but also provide for a vehicle for the assembly of clinical data about the population within the region for long term improvement of clinical outcomes, which in turn should improve the overall health status of the population.

We are willing to assist in the establishment of such a network in any manner that is reasonable considering our mission and financial situation. We hope to work with your office to better understand what opportunities may exist to fund the implementation and ongoing support for such a network.

We are proposing to provide access to our Personal Health Record for the citizens in Columbia County for up to 200 concurrent log-ins per month. This constitutes an in-kind contribution as follows:

Software License Cost = \$36,000 annually  
Software Support Cost = \$24,591 annually  
Hosting Services = \$18,000 annually  
Internal Support Costs = \$64,000 annually  
Total = \$142,591 annually

Sincerely yours,

A handwritten signature in black ink, appearing to read "Harold H. Scott".

Harold H. (Hal) Scott

1515 Pope Street, FG-2238, Augusta, Georgia 30912 706-721-9674 Fax 706-721-0620 mcghealth.org

Delivering health care for the Medical College of Georgia

**Grant Proposal – Network Operations/Data Processing Center/Public Computer Center**

**Purpose:** To establish a transitional broad band network operations/data processing/public computer center that would provide centralized network connectivity and data processing capability to rural healthcare providers in east Georgia.

**Amount to be requested:** \$8M

**Proposal Due Date:** TBD

**Description:** The funding made available under this program will be used to equip and operate a network operations/data processing center (NOC) that would be operated by a not-for-profit business entity that would provide network support and data processing services to health care providers in rural east Georgia. This NOC would be situated in the region in such a way that reliable services could be provided within the geographic coverage area.

The initial build out and operations of the NOC would be funded by this grant, however, the ongoing operations would be funded through subscriptions paid by the participants who make use of the service provide by the NOC. The provisions of the American Recovery and Reinvestment Act of 2009 include the payment of stimulus funds to healthcare providers who are meaningful users of health information technology. The NOC would provide access to certified HIT products for provider in the geographic coverage so they could become qualified for these stimulus funds. Once qualified the providers would be required to maintain the subscription to remain qualified.

MCG Health, Inc. the not-for-profit business entity that supports the Medical College of Georgia the region's only academic medical center has agreed to oversee the acquisition and operation of the NOC using funds from this grant and ongoing subscriptions for service. The NOC would be located in Columbia County and utilize the broad band infrastructure created under Columbia County broadband proposal.

MCG Health, Inc. would provide ongoing operating costs for the facility for ten years at a maximum cost of \$180,000 per year. At the end of ten years ownership of the facility would transfer to MCG Health, Inc.

**Consortium Members:** MCG, MCG Health, Inc.; East Georgia Health Cooperative, Columbia County, Georgia.

Estimated cost for supervision of acquisition and build out.	\$ 113,400
Ongoing annual operating cost estimates (Not to exceed) (10 Years)	<u>\$1,800,000</u>
Total In-Kind Contribution	<u>\$1,913,400</u>

May 29, 2009

Lewis Foster  
IT Manager  
Columbia County Board of Commissioners  
PO Box 498  
630 Ronald Reagan Drive, Building C  
Evans, GA 30809

**Re: Columbia County Expansion and Stimulus Package**

Dear Mr. Foster:

I am writing with regard to Columbia County's interest in extending competitive broadband facilities to underserved or unserved areas within the county. Knology hereby expresses its interests in pursuing projects with the County to expand its service into these areas. Knology will need to work with the County to confirm the scope and economics of the project before formally committing its resources. We look forward to working with Columbia County to bring broadband services to additional areas.

Please let us know how you would like to proceed with these projects.

Very truly,



Chad S. Wachter  
Vice President and General Counsel

cc: Mike Adams  
Debbie Larkin  
Michael Lamar

## Foster, Lewis

---

**From:** Mike Adams [Mike.Adams@knology.com]  
**Sent:** Wednesday, August 05, 2009 1:43 PM  
**To:** dwilson@engineeringassociates.com  
**Cc:** Foster, Lewis  
**Subject:** Estimate to lease fiber from County

In reviewing the map of the Columbia County fiber network, there were three areas of interest that Knology would primarily be interested in servicing. Those areas included Harlem, Grovetown and the Greenbrier areas of the county, with the County fiber network serving as a transport link from the existing Knology network. Our engineering dept. estimated that we would utilize 25 fiber miles using 12 fibers at a lease cost of \$12,000 per month, and under a 60 month lease term with total cost of \$720,000. I hope this is what you were looking for, if not please advise.



*August 6, 2009*

Mr. Lewis Foster  
IT Manager - Columbia County  
630 Ronald Reagan Drive  
Building C – 3<sup>rd</sup> Floor  
Evans, GA 30809

**RE: Broadband Federal Stimulus Application**

Dear Mr. Foster:

On behalf of the Development Authority of Columbia County, the entity charged with advancing commerce and industry within the county, please accept this letter in support of your division's application for assistance through the Broadband Technology Opportunities Program Grant program. In the arena of economic development, reliable broadband service and access is vital for business growth – growth that can lead to greater employment opportunities for residents in the county and to an increased level of capital investment in the community.

Furthermore, fast and dependable broadband for all areas of the county allows our local education partners (at the elementary, secondary, and post-secondary levels) to provide students and workers with the proper training and education needed to exist in today's high technology world. As more education programs are instituted on-line and via specialized web portals, the need for broadband will become critical to the county's economic survival.

Attached to this letter is a brief narrative highlighting planned developments within Columbia County, those which are especially dependent upon quality broadband access. Should you or anyone reviewing this narrative have a question or comment, please contact me directly at the following e-mail address: [tpost@ColumbiaCountyGA.gov](mailto:tpost@ColumbiaCountyGA.gov).

Thank you for taking the initiative on this vital component of economic development.

Yours truly,

Troy Post, CEcD  
Executive Director  
Development Authority of Columbia County (DACC)

## **Implications for Economic Development via Greater Broadband Access in Columbia County**

**Position paper of the Development Authority of Columbia County (DACC)**

The extension of broadband service to all areas of Columbia County (GA) – a significant portion of which, according to the U.S. Department of Agriculture, can be considered “rural” – will permit the feasible development of business sites in those areas, therein leading to the creation of job opportunities for areas that have historically lagged behind the economic development of the more urban areas of the county. The extension of broadband will also increase the capabilities of businesses and residents to access the specialized education and training services that are becoming increasingly available on-line, thereby ensuring that these firms and citizens have the skills and talents necessary to compete in the 21<sup>st</sup> Century workforce.

Broadband service – as an inducement for locating and situating businesses within these rural areas of the county – has become an integral part of the economic development world. Quite simply, those communities that cannot offer to businesses and residents access to such service will be communities that languish economically. Therefore, it is important to identify ways in which Columbia County can overcome this barrier and provide the capability for county-wide broadband service.

Such service will become a critical factor in determining whether several future, planned developments come to fruition. Below is a sample of three such planned developments, each of which the Development Authority of Columbia County (DACC) hopes to facilitate over the next five-to-ten years:

- The creation of a new, mixed-use “mega-site” business park, located near Exit #183 of Interstate 20. This potential project, which could encompass more than 1,000 acres, would be designed for light industry, distribution, and a small number of energy-related firms (in the agri-business sector). Plans also call for the development of a small retail/lodging component within the park. Broadband access will be a critical infrastructure feature for businesses in the park, similar in importance to the park’s interior roadways and its utility (water, sewer) access and capacity.
- The creation or expansion within the county of a business incubator program, with satellite operations (or business accelerators) in two or three business parks in the western and southern ends of the county. The concept of the business incubator is a well-proven method of growing new firms and creating job opportunities where previously such opportunities did not exist. In this planned project, broadband access would permit tenant companies to operate from minimal space within an incubator facility and pay a reduced rate for such services, thus permitting more money to be invested in product and market development – key areas to ensure business survival.

- The establishment of a resort or lodging retreat along the shores of Clark's Hill Lake in the northern part of the county. [Clark's Hill is one of the largest freshwater bodies of water in the Southeastern U.S.] The lodging industry now requires reliable broadband access at all hotel/lodging sites, in order to attract the high-return business sector clients (especially those corporate accounts needing conference and meeting space). The county is currently negotiating with the U.S. Corps of Engineers (which operates the land surrounding the lake) to develop a lodge and conference site on the water, one that could be used for both recreation and business purposes – thereby generating a significant economic benefit for the county.

However, without quality broadband service (one that can offer affordable, fast, and dependable access), none of these potential development projects will materialize.

It is therefore the position of the DACC that it work closely with county and state officials to advance and support at all times any projects or proposals that will help to extend quality broadband service throughout the county.

For questions or comments about this position paper, please contact Troy Post of the DACC at 706-312-1375, or electronically at [tpost@ColumbiaCountyGA.gov](mailto:tpost@ColumbiaCountyGA.gov).



ATG Communications, LLC  
753 Broad Street  
Augusta, GA 30901  
(706) 823-1449

Tuesday, August 11, 2009

Lewis Foster

IT Manager

Columbia County Board of Commissioners

Evans, GA

Mr. Foster,

I am writing this letter of support for the stimulus grant application you and your team are preparing for Columbia County, that will build out 200 miles of fiber optic cable and 5 multi-use communication towers. As ATG is a company that owns and operates a microwave broadband access network providing broadband services to the unserved and underserved areas of Richmond, Columbia, Lincoln, Burke, and McDuffie, and Jefferson counties, this infrastructure of fiber optic cable and additional communication towers, will allow ATG to better serve the business and government communities of not only Columbia county but also allow ATG to better serve the surrounding rural counties with more redundancy and faster speeds from our network.

ATG would be interested in working out a partnering agreement where, as ATG would service and maintain the vertical assets in exchange for a defined amount of space on said towers. The benefit to the county is that they would have a minority owned business as a partner in this project that can bring a value to the county by maintaining or adding additional jobs as well as the ability to manage and maintain these new vertical assets.

Sincerely

A handwritten signature in black ink, appearing to read "Graham Ellison".

Graham Ellison

CC: Robin Hall

CC: Lottie Ellison



**AUGUSTA**



**TECHNICAL  
COLLEGE**

ESTABLISHED 1961

*A Unit of the Georgia Department  
of Technical and Adult Education*

3200 Augusta Tech Drive  
Augusta, GA 30906  
(706) 771-4000 tel  
(706) 771-4016 fax  
[www.augusta.tcc.ga.us](http://www.augusta.tcc.ga.us)

**July 27, 2009**

**Lewis Foster  
IT Manager  
Columbia County Board Of Commissioners  
630 Ronald Reagan Drive  
Building C 3rd Floor  
Evans, GA 30809**

**This letter is intended to support the application of Columbia County for a Broadband Network Grant through the American Recovery and Reinvestment Act.**

**We believe this Broadband Network will improve the quality of life in the community especially for vulnerable populations. We believe the project will provide and significantly enhance the quality of life in the community including improvement in, public safety, expand educational opportunities, improve medical support, support commercial expansion and help generate additional employment opportunities, especially for vulnerable populations by making this region more competitive for potential employers.**

**The college believes that this grant would be supportive of our college initiative to expand educational offerings into Columbia County.**

*Sincerely,*

A handwritten signature in black ink, appearing to read 'Terry D. Elam', with a long, sweeping underline.

**Terry D. Elam  
President**



# CITY OF GROVETOWN

103 Old Wrightsboro Road  
P. O. Box 120  
GROVETOWN, GEORGIA 30813



July 24, 2009

Dear Sir or Madam:

It is the intention of the City of Grovetown to support the application of Columbia County for a Broadband Network Grant through the American Recovery and Investment Act. We have reviewed the Network Plan and intend to become a customer or user subject to appropriate pricing and contract terms.

Our plans are to reach out to both our young citizens as well as our senior citizens; we believe this project will provide great opportunities for our citizens. This project will improve the quality of life in our community to include education, employment opportunities and public safety.

The City of Grovetown has grown significantly in the last five years our population in the 2000 census was 6089 now we are near 10,000 citizens in our city. As our city grows we also will also need to keep up with the many technology changes around us.

Please contact Shirley Beasley, City Administrator (email [ShirleyBeasley@grovetownga.us](mailto:ShirleyBeasley@grovetownga.us)) or Vicky Capetillo, City Clerk ([clerk@grovetown.ga.us](mailto:clerk@grovetown.ga.us)) or at 706-863-4576 mailing address of City of Grovetown, P.O. Box 120, Grovetown, Georgia 30813.

Sincerely,

George James  
Mayor



# CITY OF GROVETOWN

103 Old Wrightsboro Road  
P. O. Box 120  
GROVETOWN, GEORGIA 30813



June 17, 2009

Dear Sir or Madam:

The City of Grovetown strongly supports the Broadband Technology Opportunities Program Grant Application submitted by the Columbia County Board of Commissioners to serve Columbia County Georgia. As the Mayor of the City of Grovetown, I understand the need for businesses to have access to Broadband and how vital it is to our city to maintain the businesses we currently have and to bring new business to the city.

Not only will Broadband allow our business community to prosper by expanding the workforce, it will allow the employees to expand their education to ensure the necessary skills in today's workplace.

I along with the City Council and citizens of Grovetown respectfully request your support and approval of the grant application. I feel the availability of broadband access will greatly improve our local economy.

Sincerely,

A handwritten signature in black ink, appearing to read "George James". The signature is fluid and cursive, extending across the width of the page.

George James  
Mayor



August 13, 2009

320 N. Louisville Street  
P.O. Box 99  
Harlem, GA 30814

1-706-556-3448  
Fax: 706-556-3293  
www.harlemga.org  
E-mail: cityofharlem@harlemga.org

Dear Sir/Madam:

This letter is intended to support the application of Columbia County for a Broadband Network Grant through the American Recovery and Reinvestment Act. We have reviewed the Network Plan and may become a customer subject to the appropriate pricing, locations and contract terms.

As Mayor of the City of Harlem, I understand that quality and reliable broadband access is a tool that our current and future employers will increasingly require. Broadband access is important to our efforts to serve our existing businesses and its availability will be a factor in our efforts to recruit new jobs to our area.

In addition to its role as a tool for job creation, broadband access will allow for greater educational and workforce development opportunities for our community. This will enable us to expand our educational and work force development efforts to train workers and ensure they have the skills necessary to compete in today's job market.

We hope you will approve this application and support our efforts to create jobs while improving broadband access for our citizens.

Thank you for your time and consideration. If you have any questions or need any additional information, please do not hesitate to call me or Jean Dove, City Manager, (706) 556-0043.

Sincerely

A handwritten signature in black ink, appearing to read "Robert W. Culpepper".

Robert W. Culpepper  
Mayor





## COLUMBIA COUNTY SHERIFF'S OFFICE

Clay N. Whittle, Sheriff  
2273 COUNTY CAMP ROAD  
POST OFFICE BOX 310  
APPLING, GEORGIA 30802-0310  
(706) 541-1043



August 3, 2009

Mr. Lewis Foster, IT Manager  
Information Technology  
Columbia County Board of Commissioners  
P.O. Box 498  
Evans GA 30809

**COMPUTER ORI**  
GA 0360000

**OFFICE FAX:**  
(706) 541-4059

**JAIL FAX:**  
(706) 541-1740

### COMMAND STAFF

**Lou Ciarnillo, CHIEF DEPUTY**  
(706) 541-4041

**Mike Adams, MAJOR**  
MANAGEMENT SERVICES  
BUREAU  
(706) 541-4053

**Rick Whitaker, MAJOR**  
FIELD OPERATIONS  
BUREAU  
(706) 541-3981

**John Wheeler, MAJOR**  
DETENTION AND  
COURT SERVICES BUREAU  
(706) 541-3920

**Dan Barnett, CAPTAIN**  
INTELLIGENCE UNIT  
(706) 541-4055

**Bill Probus, CAPTAIN**  
PATROL DIVISION  
(706) 541-3877

**Steve Morris, CAPTAIN**  
INVESTIGATIONS DIVISION  
(706) 541-4050

**Donna Dunham, CAPTAIN**  
OFFICE OF PROFESSIONAL  
STANDARDS  
(706) 541-3918

**Jim Leonard, CAPTAIN**  
DETENTION/ADMINISTRATIVE  
& COURT SERVICES  
(706) 541-3917

**John Whittle, CAPTAIN**  
SPECIAL OPERATIONS  
DIVISION  
(706) 541-4055

**Clay Smith, CAPTAIN**  
ADMINISTRATIVE SERVICES  
DIVISION  
(706) 541-4027

**Brett Carani, CAPTAIN**  
DETENTION CENTER  
OPERATIONS  
(706) 541-3920

Dear Mr. Foster,

The intent of this letter is to strongly support Columbia County's application for a Broadband Network Grant through the American Recovery and Reinvestment Act. I have reviewed the Network Plan and believe that becoming an anchor tenant for broadband service will enhance the Columbia County Sheriff's Office in a number of areas, specifically the following:

- Vastly improved communications
- Quicker response times
- Better connections for the mobile data terminals
- Traffic management at major intersections

Broadband service would also provide the Columbia County Detention Center with telemedicine capabilities, thus reducing the number of prisoner transports to medical facilities.

The above-mentioned upgrades to public safety capabilities would improve the quality of life for all citizens of Columbia County, and I fervently support the grant application.

Very truly yours,

A handwritten signature in black ink, appearing to read "Clay N. Whittle".

Clay N. Whittle  
Sheriff

CNW:cdp



July 23, 2009

Columbia County Board of Commissioners  
Information Technology  
Lewis Foster IT Manger  
PO Box 498  
Evans, GA 30809

Dear Mr. Foster:

As the division director the Emergency and Operations Division, I would like to extend my support for Columbia County's application for a *Broadband Network Grant through the American Recovery and Reinvestment Act*. We have reviewed the Network Plan and are exited about becoming a user of the network plan.

While managing the contracts for the Fire Department and EMS Service provider, the Columbia County Emergency and Operations Division consist of several responsibilities including Animal Care & Control, Fleet Services, 3-1-1 Customer Service and Information Center, the Emergency Management Agency, Emergency Operations Center, Mobile Operations Center, Risk Management, Senior Center, Public Transit as well as administrative oversight of state agencies such as Public Health, Department of Family and Children Services, and Georgia Forestry. Each of these departments will have much greater opportunities to include safety and efficiency which will be a direct benefit to citizens.

Along with providing vulnerable populations in our community with quality of life improvement, this Broadband Network will also greatly improve public safety, expansion of educational opportunities, improved medical support, support of commercial expansion, and help generate additional employment opportunities, particularly for vulnerable populations by making this region more competitive for potential employers.

This Broadband Network Plan is a great opportunity and will be a tremendous benefit to our citizens.

A handwritten signature in black ink that reads "Pam Tucker". The signature is fluid and cursive, with the first name "Pam" and last name "Tucker" clearly distinguishable.

Pam Tucker  
Emergency and Operations Division Director  
P. O. Box 498  
Evans, GA 30809  
706-868-3303 Office  
706-868-3343 Fax  
[ptucker@columbiacountyga.gov](mailto:ptucker@columbiacountyga.gov)

A Community of Pride • A County of Vision • Endless Opportunities

P.O. Box 498 • 650-B Ronald Reagan Drive • Evans, Georgia 30809 • phone: 706-868-3303 • fax: 706-868-3343

[www.columbiacountyga.gov](http://www.columbiacountyga.gov)



**Georgia State Patrol**  
**1060 Monticello Hwy.**  
**Madison, Georgia 30650**

*Troop Commander:*  
*Captain W.H. Ashburn #15*

*Phone: (706) 343-5870*  
*Fax: (706) 343 5880*

*Ass't Troop Commanders:*  
*Lt. D.D. Smith #43 – Lt. A.P. Carrier #44*

August 4, 2009

**TO** : Columbia County Board of Commissioners  
Lewis Foster, IT Manager

**FROM** : Lt. D. D. Smith #043  
Asst. Troop E Commander

**SUBJECT** : Broadband Network Grant

This letter is intended to support the application of Columbia County for a Broadband Network Grant through the American Recovery and Reinvestment Act. We have reviewed the Network Plan and intend to become a customer or user subject to appropriate pricing and contract terms.

We believe this Broadband Network will improve the quality of life in the community now underserved by existing technologies. Being a public safety provider, we are providers of information that can be life saving to those in underserved areas. We chose to partner with the Columbia County Government as one of their proposed towers will be close to our new facility in the ever growing area of Chamblin Road.

Our existing demand for access to the internet is increasing as we move to a paperless organization. Our new regional communications center is covering 21 east Georgia Counties and the demand for a safe, reliable broadband system cannot be understated. This connection is the lifeline between our systems and the Troopers in the field.

Our organization is willing to work with Columbia County in any way to facilitate this process. We fully support the efforts to expand this much- needed service.

*Trust*

*Fortitude*

*Compassion*

*Professionalism*

**Paul D Cooper**  
Chief

James W Champion  
Assistant Chief

J David Butler,  
Administrator



3910 Desoto Drive  
Martinez, GA 30907  
Tel. (706) 863-7745  
FAX (706) 863-7015

Remit to:  
P.O. Box 204231  
Martinez, GA 30917-4231

July 23, 2009

Columbia County Board of Commissioners  
Information Technology  
Lewis Foster IT Manger  
PO Box 498  
Evans, GA 30809

Dear Mr. Foster:

This letter is intended to support the application of Columbia County for a *Broadband Network Grant through the American Recovery and Reinvestment Act*. We have reviewed the Network Plan and intend to become a customer or user subject to appropriate pricing and contract terms.

We believe this Broadband Network will improve the quality of life in the community especially for vulnerable populations. We believe the project will provide a significantly enhance the quality of life in the community, including improvement in public safety, expansion of educational opportunities, improved medical support, support of commercial expansion, and help generate additional employment opportunities, particularly for vulnerable populations by making this region more competitive for potential employers.

The Fire Department uses a vast array of technology solutions to enhance services to the community we serve. We have been limited in our abilities due to the lack of services available in areas of the community that are underserved. Some of the projects that would benefit from this project are: information sharing with the community, greater outreach for our fire prevention programs, improved availability of our mapping and GPS responses systems, and improved ability to train response personnel on a consistent basis.

Sincerely,

A handwritten signature in black ink that reads "Paul D. Cooper".

Paul D. Cooper, Chief  
Martinez Columbia Fire Rescuc





**DEPARTMENT OF THE ARMY**

SAVANNAH DISTRICT, CORPS OF ENGINEERS  
J. STROM THURMOND LAKE  
510 CLARKS HILL HWY  
CLARKS HILL, SC 29821-9703

August 5, 2009

SUBJECT: Subject: Columbia County Broadband Network Grant

Lewis Foster  
IT Manager  
Columbia County Board Of Commissioners  
630 Ronald Reagan Drive  
Building C  
Evans, GA 30809

Mr. Foster:

This letter is intended to support the application of Columbia County for a Broadband Network Grant through the American Recovery and Reinvestment Act. We support Columbia County running fiberoptics to public property on Thurmond Project, particularly to Thurmond Dam area and Wildwood Park.

Having a Broadband Network would allow for services to be provided to the public that have not been readily available. It would also enable the US Army Corps of Engineers and Columbia County to better coordinate public safety and law enforcement services. The US Army Corps of Engineers is willing to work with the County to coordinate easements required for installation of the fiberoptics on Thurmond Project lands.

If you have any questions or require further information, please contact Park Ranger Jill Davis at 1-800-533-3478, extension 1138.

A handwritten signature in black ink, appearing to read "A. Wahus".

AARON P. WAHUS  
Project Operations Manager



## GEORGIA DEPARTMENT OF LABOR

585 RESEARCH DRIVE, SUITE D ♦ ATHENS, GEORGIA 30605  
(706) 425-3128 / Fax (706) 425-3132

**MICHAEL L. THURMOND**  
COMMISSIONER

July 31, 2009

Columbia County Board of Commissioners  
Information Technology  
Post Office Box 498  
Evans, Georgia 30809

Dear Commissioners:

The Georgia Department of Labor (GDOL) commends Columbia County Board of Commissioners' efforts to secure a Broadband Network Grant through the American Recovery and Reinvestment Act. We have reviewed the Network Plan and offer our support in assisting wherever possible. We believe this Broadband Network can improve the quality of life in the area -- particularly for vulnerable populations. The project can significantly enhance public safety, educational opportunities, medical support, commercial expansion and employment opportunities -- accordingly making the region more appealing to potential employers. We are especially interested in your plans to partner with various agencies to provide computer labs to aid the unemployed and other vulnerable populations with training and job-search.

The mission of the Department is to work with public and private partners in building a world-class workforce system that contributes to Georgia's economic prosperity. We help individuals attain their work goals and increase independence and self-sufficiency through employment, training, comprehensive rehabilitation, and support services. GDOL also helps employers meet their business needs through employee recruitment and selection services, workforce information, and technical support.

The array of services available at our 53 career centers includes:

- Individual job search assistance and career counseling from highly trained professionals.
- Vocational rehabilitation services and job search for people with disabilities.
- Free access to PCs, laser printers, résumé writing software, internet, e-mail, telephone, and fax.
- Self-help library of books, videos, software and career exploration tools.
- State-of-the-art equipment for customers with visual and/or hearing impairments.
- Information on and referral to Job Corps, Workforce Investment Act and other Federal training programs.
- Linkage to the Georgia Career Information System (GCIS) -- an interactive PC application for gathering information on occupations, education and training programs, schools, and financial aid.
- Labor market information on demand occupations, employment trends, etc.
- Training and testing space, as available.
- Workshops on résumés, interviewing, networking, online applications, and work ethics.

As the Director of the GDOL District 4-North region, whose service area includes Columbia County, I look forward to playing a part in the success of your Broadband Network initiative.

Sincerely,

Fred Smith  
District Director, 4-North



August 11, 2009

Lewis Foster, IT Manager  
Columbia County Board of Commissioners  
630 Ronald Reagan Drive  
Building C 3<sup>rd</sup> Floor  
Evans, GA 30809

RE: Support for Columbia County Broadband Project

Dear Mr. Foster:

The Columbia County Chamber of Commerce is supportive of the County's plans to expand our Internet utility with a \$15,000,000, 20% matching Stimulus Grant. I have spoken with Mike Adams of Knology who is supportive of this Internet project. AT&T provided a formal statement that it is only supportive if the project does not have a significant effect on private business or competition. AT&T is supportive of using public funds for un-reached areas in the county. Comcast agrees with the AT&T position. As long as the county is able to work in reasonable harmony with the Columbia County business community then we are in support of this project.

We are excited about the spread of internet capability into the 60% of the county that is currently underserved. This expansion will add jobs to our area. We desire for these new jobs to be local people.

We understand this project will provide for continued private competition and help to maintain reasonable pricing for consumers. We also see in your plan that internet access will be made more available in Libraries and Senior Centers. Other benefits expected are E-Government and Civic Participation, Telemedicine and independent living aids, better disaster alternative communications and many others.

The Chamber is generally in favor of less government spending and more private market solutions. We understand that this project appears to make good business and community sense. We do desire for any long term County services that are established out of this project to be self sustaining from the anchor customers.

Please let us know how we can be of further assistance.

Sincerely,

A handwritten signature in black ink that reads 'Jim Tingen'. The signature is written in a cursive style with a long, sweeping underline.

Jim Tingen  
Executive Director  
Columbia County Chamber of Commerce  
706-860-4735

May 6, 2009

This letter is in support of Columbia County's application to expand wireless internet in the rural areas of the county. Our organization works with many of the underserved groups in Harlem and the surrounding area such as senior citizens, economically disadvantaged families and low-income youth.

Many of the more than 250 youth we serve do not have access to computers with internet service outside of school. The local library only has four connected computers and its hours are limited. We did a survey with the youth we serve and three out of four said they did not have a computer for homework. This expansion would make a huge difference in the lives of these young people.

The City of Harlem is in the process of building a senior citizens center and one of the services that seniors have indicated they would like to have is computer access.

Our organization is willing to work with Columbia County in any way to facilitate this process. We fully support the efforts to expand this much-needed service.

Sincerely,

**Julie K. Miller**  
Executive Director

PO Box 99, Harlem, GA 30814  
connectcolumbia@yahoo.com  
706.556.0609 phone

405 A West Church Street - office  
www.gafcp.org/fcnetwork/columbia  
706.556.1629 fax (501c3)



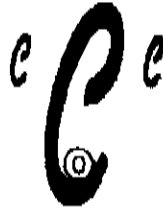

**Columbia County Cares, Inc.**

1959 Appling-Harlem Road - Appling, GA 30802 - (706) 541-2834

**August 4, 2009**

To Whom It May Concern,

Columbia County Cares is a non-profit organization dedicated to help feed the less fortunate people of our county. Many of our clients are unemployed or underemployed and have no means of improving themselves so we whole heartily endorse the Broadband Stimulus Program for training of the people of our county.

I can see a real benefit to many of our clients who have no way to get an education of any sort, which may improve their situation in life. This program can teach people a useful career particularly with the growing amount of expertise that is needed in the computer field.

Thank you for your consideration,

Lou Reda

Director of Columbia County Cares

July 23, 2009

Dear Sir or Madam:

I am writing in support of the Broadband Technology Opportunities Program Grant Application submitted by the Columbia County Board of Commissioners. The Columbia County Community Broadband (CCCB) project will benefit our community in a variety of ways. Mr. Lewis Foster and his team have developed an exciting vision for public-private cooperation in providing a 21<sup>st</sup>-century resource to a broad cross-section of the local population

The two most concrete results of the CCCB will be installation of in excess of 200 miles of fiber throughout the county and provision of free high-speed wireless access in a number of public locations—parks, community centers and the like. Though these are only the most obvious outcomes, they are worthy of support in and of themselves.

Many of Columbia County's citizens live in low-density areas in which it is not possible for a private provider to sell broadband at an accessible price. With the county providing leased access to high-capacity trunks throughout the county, the county can fund the ongoing maintenance of those lines, the service provider expands its customer base, and the subscriber has high-speed Web access at prices more in line with common tariffs in high-density population areas. Free wireless access at parks and community centers is an obvious benefit to all citizens and probably needs no further elucidation here.

Beyond those two concrete outcomes, however, the CCCB project will also promote greater community ties with schools like Augusta Preparatory Day School. Although final details of Augusta Prep's participation in the CCCB would need to be determined once the project has its final form and has been funded, Augusta Prep is a school that places a high value on community service. The sort of community outreach at envisioned by Mr. Foster and his team is certainly very much in line with Prep's community service programs now in place. Donation of decommissioned school equipment (e.g. desktop and laptop computers) would also be consistent with the school's practice in reaching out to the surrounding community.

Finally, the CCCB will rely on partnership with local entities who wish to establish tenancy on the CCCB trunks, to provide a revenue stream for maintenance of the CCCB. Again, any final determination on Augusta Prep's part would be pending the details of such an agreement, but the school would be very interested in having that conversation. Prep students' use of online research facilities and educational content has exploded in recent years and any means of providing additional resources is of great interest to us.

In sum, the CCCB proposal represents a thoughtful approach to providing a substantial benefit to Columbia County citizens on a variety of levels. Mr. Lewis and his team have developed a framework that will benefit the county in terms of finance, connectivity and education. I commend the team for its hard work and am pleased to offer my support of the project.

Respectfully,



Anthony Shaffer  
Director of Technology  
Augusta Preparatory Day School

August 7, 2009

To whom this may concern:

I am the Columbia County Library Manager. I am very supportive of Columbia County applying for the Broadband Stimulus Grant.

I am in charge of 3 library branches, two which are on rural areas of the county. By bringing broadband to all of Columbia County, we will be able to provide internet access to the patrons at each library as well as the public areas of the community like the Community Centers, Senior Centers, as well as the parks. We will also be able to hold computer classes for our patrons in resume 'writing, GED classes for those who need them as well as Microsoft Office classes, and many other classes as the need become available.

I believe the Broadband Network will improve the quality of life in the community especially for vulnerable populations. I believe the project will provide a significant enhancement to the community including improvement in, public safety, expanded educational opportunities, improved medical support, support of commercial expansion and to help generate additional employment opportunities by making this region more competitive for potential employers.

Thank you for your time,

Mary Lin Maner, SLIS  
County Library Manager  
Columbia County Libraries  
7022 Evans Town Center Blvd  
Evans, GA 30809  
mlmaner@columbiacountyga.gov



Grant Application Reviewer(s),

This letter is intended to support the application of Columbia County for a Broadband Network Grant through the American Recovery and Reinvestment Act. We have reviewed the Network Plan and intend to become a customer or user subject to appropriate pricing and contract terms.

We believe this Broadband Network will improve the quality of life in the community especially for vulnerable populations. We believe the project will significantly enhance the quality of life in the community including improvement in, public safety, expanded educational opportunities, improved medical support, support commercial expansion and help generate additional employment opportunities, especially for vulnerable populations by making this region more competitive for potential employers.

Our senior population would benefit from cost effective, fast network access to the digital world. This access would allow easy access to educational opportunities, entertainment, and digital commerce.

Funds secured from this grant would be used to develop a senior computer lab and classes at our Senior Center. Potential uses include the development of senior web classes that instruct seniors on online commerce and research for medical and lifestyle decisions.

We hope to succeed in securing this grant to help develop better access for our senior clients and offer expanded access to the digital world that is ever increasingly important to a modern lifestyle.

Respectfully,

A handwritten signature in black ink, appearing to read "M. Jeff Asmann", written over a light blue horizontal line.

M. Jeff Asmann

Senior Center Manager

A Community of Pride

• A County of Vision

• Endless Opportunities

---

P.O. Box 498 • 5913 Euchee Creek Drive • Grovetown, Georgia 30813 • phone: 706-556-0308 • fax: 706-556-8973

[www.columbiacountyga.gov](http://www.columbiacountyga.gov)





## EUCHEE CREEK LIBRARY

August 7, 2009

Dear Sir or Madam,

Please accept this letter as evidence of my support and endorsement of the Broadband Opportunities Program Grant Application submitted by the Columbia County Board of Commissioners. I am the manager of the Euchee Creek Library and we serve a combination of rural and suburban citizens of this county. These patrons would be well served by greater and more economical access to the flow of information that this project will foster. Additionally, this facility and our patrons will benefit through the greater educational opportunities that will be provided through the application of funds towards a computer lab that will provide hands-on experience for computer users at a variety of experience levels.

Please note that every day I am able to observe the practical benefits of the availability of online access to people who would not otherwise have access to it and I believe that continued and broader access to this resource can become a positive influence on every member of our populace.

Sincerely,  
John Welch



## Serenity Behavioral Health Systems

3421 Mike Padgett Highway Augusta, Georgia 30906-3815

Phone (706) 432-4800 Fax (706) 432-3794

*"The mission of Serenity Behavioral Health Systems is to provide the highest quality services in a professional, responsive and caring manner"*

August 7, 2009

Columbia County Board of Commissioners  
Information Technology  
Lewis Foster IT Manager  
P. O. Box 498  
Evans, GA. 30809

Dear Columbia County Board of Commissioners:

I am writing to offer my enthusiastic support for Columbia County's application for a Broadband Network Grant. It is my understanding that this grant is being offered through the American Recovery and Reinvestment Act.

If we find that the Plan will offer us appropriate pricing and contract terms, we would strongly consider becoming a full-fledged customer.

Due to Serenity's standing as the largest provider of Behavioral Healthcare in the region, we can see how such a program would provide many benefits. Our information systems needs are constantly changing and our services could be upgraded via the enhancements that a publicly owned Broadband network could provide.

Should you require additional endorsements from Serenity, please do not hesitate to contact me.

Very Truly Yours,

Charles D. Williamson  
Chief Executive Officer

CDW:yl